



AMBERAIR

EN ELECTRICAL INSTALLATION, OPERATION AND MAINTENANCE MANUAL



1. CONTENTS

| | |
|---|----|
| 1. CONTENTS | 2 |
| 2. SAFETY PRECAUTIONS | 3 |
| 3. FANS | 4 |
| 3.1. FANS WITH AC MOTORS (1 SPEED) | 4 |
| 3.2. 3.2 FANS WITH AC MOTORS (2 SPEED) | 5 |
| 3.3. FANS WITH EC MOTORS | 5 |
| 3.4. FANS WITH PM MOTORS | 9 |
| 3.4.1. VSD INTEGRATED ON MOTOR | 9 |
| 3.4.2. VSD DELIVERED LOOSE (FC101 AND FC102) | 11 |
| 4. CABLE SELECTION AND CABLE INSTALLATION | 13 |
| 4.1. THREE PHASE RECEIVER POWER SUPPLY CABLE SELECTION | 13 |
| 4.2. POWER AND CONTROL CABLE INSTALLATION | 13 |
| 5. HEAT RECOVERY SYSTEMS | 14 |
| 5.1. PLATE HEAT EXCHANGER | 14 |
| 5.2. ROTARY HEAT EXCHANGER | 16 |
| 5.2.1. 1 ~ PHASE ROTOR MOTOR (W/O CONTROL) | 16 |
| 5.2.2. 3 ~ PHASE ROTOR MOTOR (W/O CONTROL) | 17 |
| 5.2.3. 5.2.3 STEPPING MOTOR WITH CONTROLLER | 18 |
| 6. HEAT EXCHANGERS | 23 |
| 6.1. WATER HEATER | 23 |
| 6.2. WATER COOLER | 25 |
| 6.3. ELECTRICAL HEATER | 25 |
| 6.4. GAS-FIRED HEATER | 26 |
| 7. HUMIDIFIERS | 27 |
| 7.1. STEAM HUMIDIFIER | 27 |
| 7.2. EVAPORATIVE HUMIDIFIER | 27 |
| 8. AIR FILTER SECTION | 28 |
| 9. DAMPER SECTION | 29 |
| 10. CONTROL SYSTEM | 31 |
| 11. ACCESSORIES | 33 |
| 11.1. FAN SAFETY SWITCH | 33 |
| 11.2. SECTION LIGHTING | 33 |
| 11.3. TEMPERATURE SENSORS (WITH INTEGRATED CONTROL SYSTEM) | 33 |
| 11.4. DUCT SMOKE DETECTOR (WITH INTEGRATED CONTROL SYSTEM) | 34 |
| 11.5. CO ₂ DUCT AND ROOM SENSOR (WITH INTEGRATED CONTROL SYSTEM) | 34 |
| 11.6. HUMIDITY DUCT AND ROOM SENSOR (WITH INTEGRATED CONTROL SYSTEM) | 34 |
| 12. UNIT ASSEMBLING | 35 |
| 13. UNIT'S BASE FRAME GROUNDING | 36 |
| 14. CHECKLIST FOR UNIT START-UP AND MAINTENANCE | 37 |

2. SAFETY PRECAUTIONS

- All work in connection with the assembly, installation and commissioning of the unit must be carried out by specially trained personnel. The unit can only be taken into operation if it has been assembled in accordance with these installation and operation manual. All protective devices must be effective.
- Do not use the unit for purposes other than its intended use. Use the unit only for the air handling (air filtration, heating, cooling, humidifying, dehumidifying and mixing).
- Use special clothing and be careful while performing maintenance and repair jobs.
- Do not place fingers or other foreign objects through inlet or exhaust guards or into connected duct. Should a foreign object enter the unit, immediately disconnect power source. Before removing foreign object, make sure that any mechanical motion has stopped, the heater has cooled down and the restart of the unit is not possible.
- Do not connect to any other power voltage source than indicated in the documentation and identification plate.
- Do not place or operate unit on unsteady surfaces and base frames. Mount the unit firmly to ensure safe operating.
- Do not use water or another liquid to clean electrical parts or connections. If you notice water on electrical parts or connections, stop operating the unit.
- Do not make any electrical connections when the power is on.
- Before maintenance and repair, the unit must be switched off by the supply-disconnecting device, which must be locked with a padlock.
- Before cleaning with steam, make sure that there are no people inside the unit.
- For work on unit elements and assemblies that not covered in this document, refer to the separate manual.
- Air handling units must be properly grounded.
- Always observe all relevant local standards and statutory regulations.
- Do not use the unit if external connections are broken or damaged. If there are any defects, stop operating the unit and replace the damaged parts immediately. That can be performed only by qualified electrician

3. FANS

Direct-driven centrifugal fans (plug fans) with one of the following motor:

- AC motor;
- EC motor;
- PM motor.

Important:

Electrical connection may only be undertaken by technically trained personnel. Before making the electrical motor connections, compare the connection specifications with the specifications on the motor identification plate. Identification plate is attached on the inner side of the motor cover or provided in the technical table on the motor. Motor thermal protections (if any) must be connected to disconnect the motor from the power supply network in case of motor overheating. Electric motor must be grounded. Ground terminal or screw is designed for the motor and labelled with "PE" or symbol \oplus . If the fans safety switch is used for connection of the motor, then activation of it must be prevented during service works on the device (by attaching lock on the handle).

3.1. FANS WITH AC MOTORS (1 SPEED)

Three phase single speed motors can normally be connected for two different voltage ranges (connection in star - higher voltage, or delta - lower voltage).

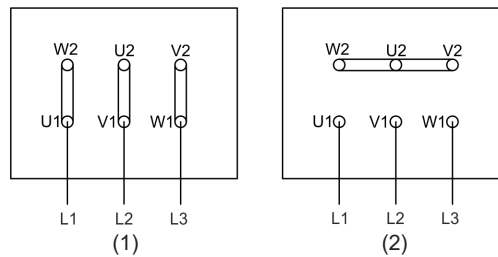

Figure 3.1.1 – AC motor (1 speed) wiring diagram for Delta (Δ) and Star (Y) connection.

(1) - Delta (Δ) connection 230V (400V); (2) - Star (Y) connection 400V (690V).

Motor starters

Excessive motor temperature due to overloading or failure of one phase can be prevented by using a motor starter. The current at which the starter trips should be set in accordance with motor nameplate data. In certain cases a standard starter will not give sufficient protection. This applies to applications with particularly severe duties e.g. starting of loads with high inertia, with the use of inverters, and use in environments with large changes in ambient temperature. In these cases, winding protection by thermal cut-outs or thermistors should be specified.

Thermal cut-outs

Thermal cut-outs is fitted to the motor winding. When the fixed temperature is exceeded the cut-out will break an electric circuit e.g. to a contactor which will turn off the motor. The switching contact is a temperature sensitive bimetal spring.

Thermistors

Protection is provided by thermistors fitted in the frame 160 and up motor windings, together with a sensing relay. Thermistors are temperature sensitive resistors that at a certain temperature have a wide change of resistance. The sensing relay can, in turn, be used to e.g. cut off supply to the main contactor coil.

Thermal protection contacts of the motor (if any) must be connected using the terminals in the motor junction box.

NOTE: For more information, control, maintenance, diagnostics and troubleshooting refer to AC motors technical specification.

Rotation direction

Three-phase motor rotation direction can be changed by switching two of the power supply phases:

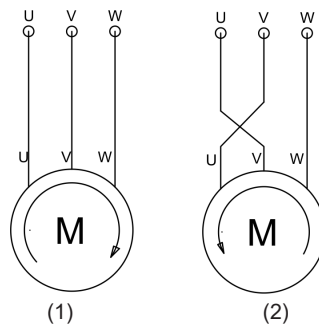

Figure 3.1.2 – Change of rotation for three-phase AC motor:

(1) – clockwise (CW) rotation; (2) – counter clockwise (CCW) rotation;

When frequency converters are used for control of AC motors, shielded cables must be used for connection. Metal cable glands (EMC) must be used at AC motors connection box. Before connecting to the motor, cables must be installed through the seals at junction box, which grounds the cable shield part.

General:

Before starting any inspection work, fans must be disconnected from voltage and all safety requirements must be followed.

Possible solutions if the fan does not rotate:

- Check connectors and contacts;
- Check if the electrical connection of the motor is correct;
- Check if the wires of the control cable is not mixed;
- Check if the voltage supplied to the motor;
- Check if motor safety switch is turned on;

After starting the device, check if:

- The motors rotate smoothly, do not vibrate and do not produce side noise;
- Airflow produced by the device matches air direction indicated on the housing;
- Thermal protections of the motor are not activated;
- Overcurrent (overload) protections of the motor are not activated;
- Motor speed changes when adjusting the control (when the device has built-in control system).

3.2. 3.2 FANS WITH AC MOTORS (2 SPEED)

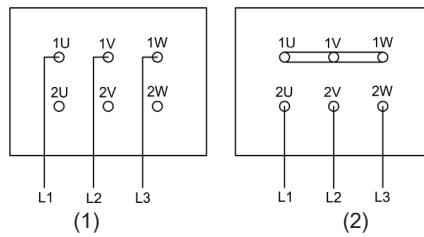

Figure 3.2.1 – AC motor (2 speed) wiring diagram:

(1) - Low speed Star (Y) connection; (2) - High speed Double Star (YY) connection.

Thermal protection contacts of the motor (if any) must be connected using the terminals in the motor junction box.

NOTE: For more information, control, maintenance, diagnostics and troubleshooting refer to AC motors technical specification.

General:

Before starting any inspection works, fans must be disconnected from voltage and all safety requirements must be followed.

Possible solutions if the fan does not rotate:

- Check connectors and contacts;
- Check if the electrical connection of the motor is correct;
- Check if the wires of the control cable is not mixed;
- Check if the voltage supplied to the motor;
- Check if motor safety switch is turned on;

After starting the device, check if:

- The motors rotate smoothly, do not vibrate and do not produce side noise;
- Airflow produced by the device matches air direction indicated on the housing;
- Thermal protections of the motor are not activated;
- Overcurrent (overload) protections of the motor are not activated;
- Motor speed changes when adjusting the control (when the device has built-in control system).

3.3. FANS WITH EC MOTORS

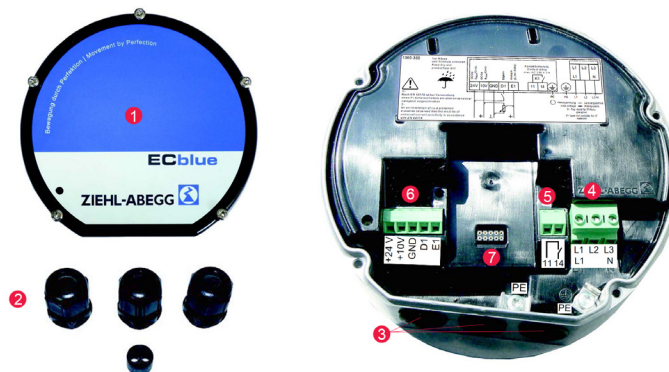

Figure 3.3.1 – EC fans with connection box (Motor size “D” and “G”):

(1) - Cover of controller housing; (2) - Cable glands + seal insert for two cables (applicable only if necessary): motor size “D”: 3 x M16 + 1 x seal insert with two holes 5 mm; motor size “G”: 3 x M20 + 1 x seal insert with two holes 6 mm; (3) - Cable entry points with plastic fastener; (4) - Mains connection; (5) - Connection alarm relay; (6) - Connection controls; (7) - Slot for add-on module.

Cable connection procedure:

1. Remove the cover from the controller housing for the connection.
2. All 3 cable entry points are in a sealed condition at delivery. Remove plastic fastener if necessary, and insert enclosed cable glands, entry points that are not used must remain sealed!
3. When using the seal insert for two cables it is not permissible to use the corresponding cable gland with only one cable.
4. Insert and connect lines correctly.
5. Attach cover of controller housing again carefully in correct position before startup.

Wiring diagram:

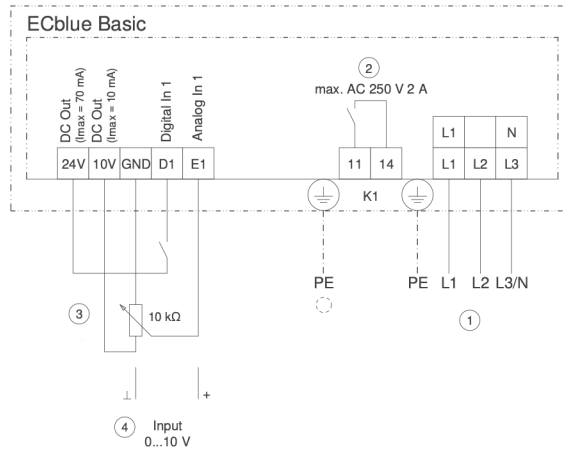

Figure 3.3.2 – EC motor (3 ~ phase) wiring diagram:

- (1) - Line voltage → Rating plate (3 ~ type not suitable for IT network); (2) - Contact rating max. AC 250V; 2A; (3) - External speed setting; (4) – Input 0...10VDC

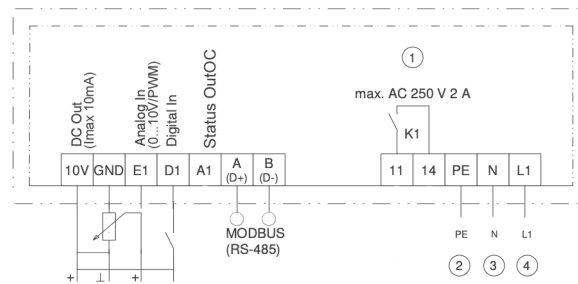

Figure 3.3.3 – EC motor (1 ~ phase) wiring diagram:

- (1) - Contact rating max. AC 250V; 2A; (2) – Ground connection terminal (PE); (3) – Neutral connection terminal (N); (4) – Phase connection terminal (L1);

Diagnostics / Faults

Status Out with flash code



Figure 3.3.4 – Status LED integrated in cover for motor size "D" and "G".

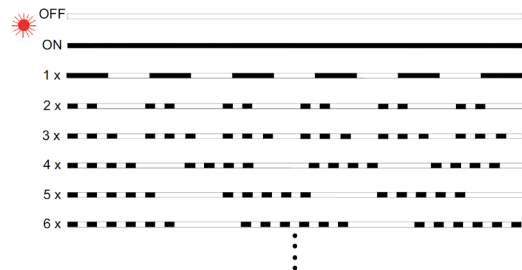

Figure C

| LED CODE | RELAYS K1* | CAUSE (EXPLANATION) | REACTION OF CONTROLLER (ADJUSTMENT) |
|----------|------------------------------------|--------------------------------|--|
| OFF | de-energized, 11 - 14 inter-rupted | no line voltage | Line voltage available? Unit switch OFF and automatically ON when the voltage has been restored |
| ON | energized, 11 - 14 bridged | Normal operation without fault | |

| LED CODE | RELAYS K1* | CAUSE (EXPLANATION) | REACTION OF CONTROLLER (ADJUSTMENT) |
|----------|---|---|--|
| 1 x | energized, 11 - 14 bridged | no enable = OFF Terminals "D1" - "24 V / 10 V" (Digital In 1) not bridged | Switch OFF by external contact (digital input). |
| 2 x | energized, 11 - 14 bridged | Active temperature management The device has an active temperature management to protect it from damage due to too high inside temperatures. In case of a temperature rise above the fixed limits, the modulation is reduced linearly. To prevent the complete system being switched off externally (in this operation permissible for the controller) in case of reduced operation due to too high an internal temperature, no fault message is sent via the relay. | With a drop in temperature the modulation rises again linear. Check cooling of the controller |
| 3 x | de-energized, 11 - 14 inter- rupted | HALL-IC Incorrect signal from the Hall-ICs, error in the commutation. Internal plug connection faulty | The controller switches the motor off. Automatic restart if no faults are recognised. Replace fan / motor |
| 4 x | de-energized, 11 - 14 inter- rupted | Line failure (only for 3 ~ types) The device is provided with a built-in phase-monitoring function for the mains supply. In the event of a mains interruption (failure of a fuse or mains phase) the unit switches off after a delay (approx. 200 ms). Only functioning with an adequate load for the controller. | Following a shut-off, a startup attempt is made after approximately 15 seconds, if the voltage supply is high enough. This keeps occurring until all 3 supply phases are available again. Check power supply |
| 5 x | de-energized, 11 - 14 inter- rupted | Motor blocked If after 8 seconds of commutation no speed is measured > 0, the fault "Motor blocked" is released | EC-Controller switches off, renewed attempt to start after about 2.5 sec. Final shut-off, when fourth starting test fails. It is then necessary to have a reset by disconnecting the line voltage. Check if motor is freely rotatable. |
| 6 x | de-energized, 11 - 14 inter- rupted | IGBT Fault Short circuit to earth or short circuit of the motor winding | EC-Controller switches off, renewed attempt to start after about 60 sec. Code 9. Final shut-off, if - following a second starting test – a second fault detection is detected within a period of 60 seconds. It is then necessary to have a reset by disconnecting the line voltage. |
| 7 x | de-energized, 11 - 14 inter- rupted | DC undervoltage If the DC-link voltage drops below a specified limit the device will switch off | If the DC-link voltage rises above the limit within 75 seconds, then the controller will attempt to start. Should the DC-link voltage stay for more than 75 seconds below the limit, the device will switch off with a fault message. |
| 8 x | de-energized, 11 - 14 inter- rupted | DC overvoltage If the DC-link voltage increases above a specified limit, the motor will switch off. Reason for excessively high input voltage or alternator motor operation | If the DC-link voltage drops below the limit within 75 seconds, then the controller will attempt to start. Should the DC-link voltage stay above the limit for more than 75 seconds, the device will switch off with a fault message. |
| 9 x | energized, 11 - 14 bridged | IGBT cooling down period | IGBT cooling down period for approx. 60 sec. Final shut-off after 2 cooling-off intervals Code 6 |
| 11 x | de-energized, 11 - 14 inter- rupted | Fault motor start If a starting command is given (enable available and Setpoint > 0) and the motor does not start to turn in the correct direction within 5 minutes, then an error message will appear | If it is possible to start the motor in the target direction of rotation after the error message, the error message will disappear. Should a voltage interruption occur in the meantime, the time taken up to the switch off will begin again. Check if motor is freely rotatable. Check if the fan is driven in reverse direction by an air stream (Behaviour in rotation by air current in reverse direction) |
| 12 x | de-energized, 11 - 14 inter- rupted | Line voltage too low If the DC-link voltage drops below a specified limit the device will switch off | If the line voltage rises above a specified limit within 75 seconds, then the controller will attempt to start. Should the line voltage stay below the specified limit for more than 75 seconds, the device will switch off with an error message |
| 13 x | de-energized, 11 - 14 inter- rupted | Line voltage too high Cause to high input voltage If the line voltage increases above a specified limit, the motor will switch off | If the line voltage drops below the specified limit within 75 seconds, then the controller will attempt to start. Should the line voltage stay above the specified limit for more than 75 seconds, the device will switch off with an error message. |
| 14 x | de-energized, 11 - 14 inter- rupted | Error Peak current If the motor current increases above the specified limit (even in a short time-frame) the device will switch-off. | After a switch off the controller waits for 5 seconds then the controller attempt a start. Arises within 60 sec. in series 5 further disconnections a final switch off with fault indication follows. Should no further switch off be exceeded in 60 sec. the counter will be reset. |

| LED CODE | RELAYS K1* | CAUSE (EXPLANATION) | REACTION OF CONTROLLER (ADJUSTMENT) |
|----------|-----------------------------------|--|--|
| 17 x | de-energized, 11 - 14 interrupted | Temperature alarm Excess of the max. permissible inside temperature | Controller switches off motor. Automatic restarting after cooling down. Check cooling of the controller |

* K1: programmed function at factory: Fault indication not inverted

Add-on modules

If required, an auxiliary module can be retrofitted to the designated slot for motor size "D", "G". The extended scope of function is specified in the documentation for the auxiliary module.

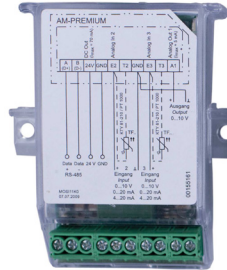

Figure 3.3.5 – 349046 Premium Module

When the auxiliary module is plugged in the fan is extended to become a full-grade multipurpose controller. For example, "Premium module" provides not only an integrated MODBUS interface, it also enables sensors to be connected straight to the fan. The module also comes with two analogue inputs and one analogue output.

Mounting the module:

Danger due to electric current

- Always read the safety instructions chapter before mounting!
- The fan in which the module is to be installed must be disconnected from the line voltage for at least 3 minutes before opening!

Attention, electrostatic sensitive devices!

- Damage to electronic components by electrostatic charging must be prevented!
- Touch the protective earth connection in the terminal to equalize the potential immediately before removing the module from the packing. This applies regardless of whether the device is already connected to the line.
- Equalize the potential again shortly before installation if the module is not installed immediately after unpacking.
- After unpacking the module, check for possible transport damage and insert it in the slot provided. Do not touch the connection!

Procedure:

Mount the module in the housing with the two enclosed screws (permissible tightening torque MA =1.3 Nm)

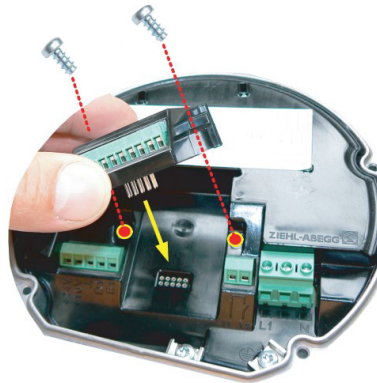

Figure 3.3.6 – Mounting the module

NOTE: For more information, control, maintenance, diagnostics and troubleshooting refer to EC motors and Add-on modules technical specification.

FanWall

For bigger air handling units, where more air flow is needed, fan wall can be selected (from 2 to 20 EC fans).

Control types for EC fan wall:

- Control with EMR'ex

No additional add-on modules are needed.

All fans are controlled with 0-10V signal.

NOTE: Breakdown of EC fan can only be recognized via fault relay.

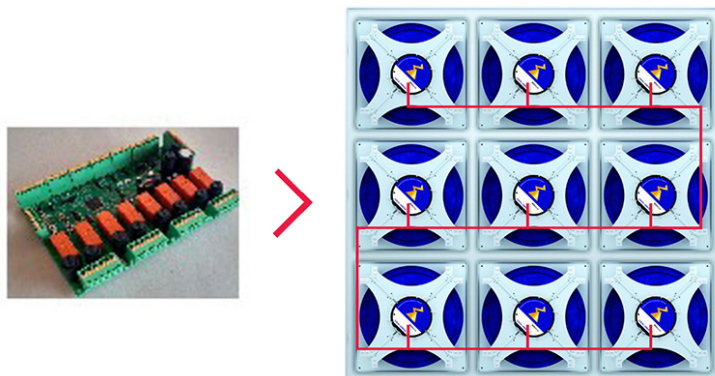

- Control with UNIcon as MODBUS Master
- All EC fans are equipped with AM-MODBUS modules.

NOTE: Breakdown of EC fan can be recognized via MODBUS communication line.

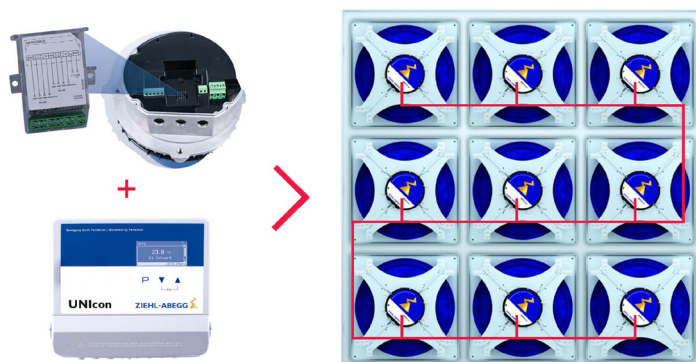

NOTE: For both control types an external control signal is needed.

For more information, control, maintenance, diagnostics and troubleshooting refer to EMR'ex and UNIcon technical specification.

General:

Before starting any inspection works, fans must be disconnected from voltage and all safety requirements must be followed.

Possible solutions if the fan does not rotate:

- Check connectors and contacts;
- Check if the electrical connection of the motor is correct;
- Check if the wires of the control cable is not mixed;
- Check if the voltage supplied to the motor;
- Check if motor safety switch is turned on;

After starting the device, check if:

- The motors rotate smoothly, do not vibrate and do not produce side noise;
- Airflow produced by the device matches air direction indicated on the housing;
- Thermal protections of the motor are not activated;
- Overcurrent (overload) protections of the motor are not activated;
- Motor speed changes when adjusting the control (when the device has built-in control system).

3.4. FANS WITH PM MOTORS

Direct on-line connection is not possible for permanent magnet motors. Speed controller is always needed. This controller has special algorithm for PM motors. Speed controller is programmed with fan and motor specific parameters.

PM motor speed controller types:

- VSD integrated on motor;
- VSD delivered loose (FC101 and FC102).

3.4.1. VSD INTEGRATED ON MOTOR

Integrated on motor means that the frequency controller is mounted at the side of the fan. If the fan service side is on the other side, the drive can easily be moved there by opening four screws. Cabling between motor and drive is already done. Built-on version is ready to be used and needs only power from mains and control signals. They can be easily connected to the terminals under the drive's plastic cover.

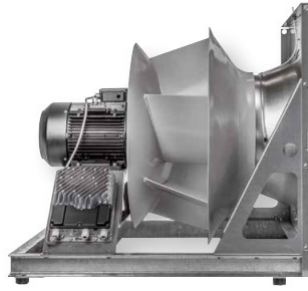

Figure 3.4.1.1 – PM motor with VSD integrated on motor

Built-on frequency controller and PM motor connection diagram

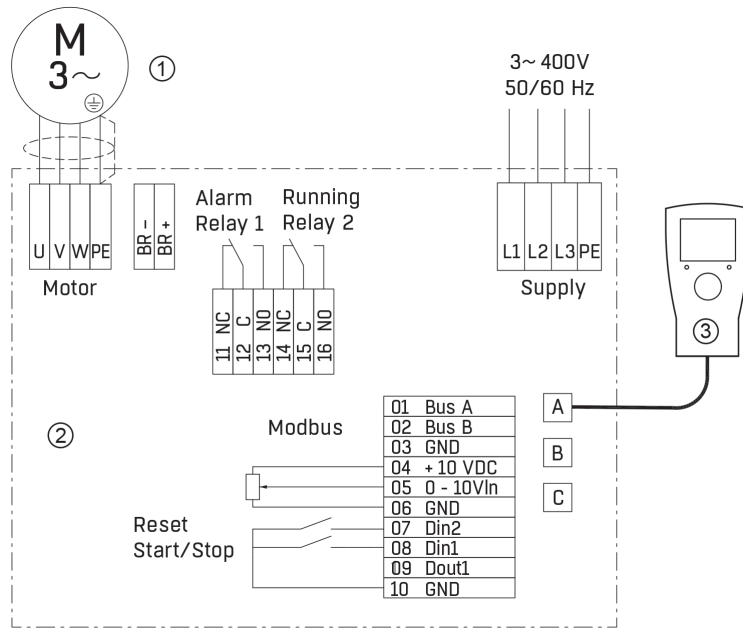

Figure 3.4.1.2 – Built-on frequency inverter and PM motor connection diagram:

(1) – PM motor; (2) – Frequency converter; (3) – Remote control (hand terminal).

Built-in protection

If the temperature inside frequency converter exceeds +95°C, the frequency converter will attempt to reduce its internal heat generation by reducing motor speed (rpm).

Frequency converter has built-in current limitation for the protection of motor and cables and cannot therefore supply more current than it is set to. In the event of lacking phase on the supply input, the frequency converter will reduce speed and activate a non-critical alarm.

The frequency converter motor output terminals are short circuit protected against phase-to-phase short circuiting.

Alarms

Frequency converter has a built-in alarm monitor, which monitors optimal fault-free operation and triggers an alarm if operating or performance problems are observed.

- "Critical" alarms stop the motor.
- "Non-critical" alarms reduce motor performance.
- The built-in alarm monitor stops the frequency converter.
- If the alarm situation passes, the alarm is automatically reset and frequency converter restarted.
- If the maximum number of restarts (5 times/60 min) is exceeded, the alarm must be reset manually. The alarm can be reset by means of a Modbus command.
- The alarm is automatically reset if the power is disconnected for longer than 60 seconds.
- Alarms can be read via Modbus.

Maintenance

Frequency converter is maintenance free under normal operating conditions and load profiles.

- The cooling fans must be kept free of dust, dirt and other foreign matter so that air can pass freely over them. Deposits of dust, dirt or other foreign matter on and between the cooling fans will prevent cooling of the frequency converter and thus impair performance.
- The cooling fans may become very hot. (Max. +95°C under normal operating conditions).
- Frequency converter cannot be repaired on site. Never attempt to repair a defective unit. Contact your supplier to obtain a replacement.

3.4.2. VSD DELIVERED LOOSE (FC101 AND FC102)



FC101 and FC102 frequency converters are delivered loose. They are to be mounted by the customer.

Figure 3.4.2.1 – PM motor speed controller: (1) - FC101 Frequency controller; (2) - FC102 Frequency controller;

Separate speed controller should be mounted near the fan. Motor cable shall not be no longer than 10 m. With longer cables some motor parameters should be changed. Speed controller is delivered with 3,5 m motor cable for fan sizes up to 050. For bigger fans motor cable length is 4,5 m.

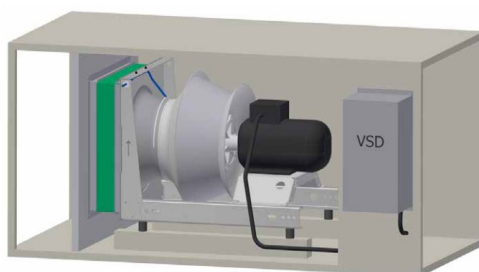

Figure 3.4.2.2 – IP54 and IP55 frequency converter mounted at AHU casing.

FC101 and FC102 frequency controller and motor connection diagram

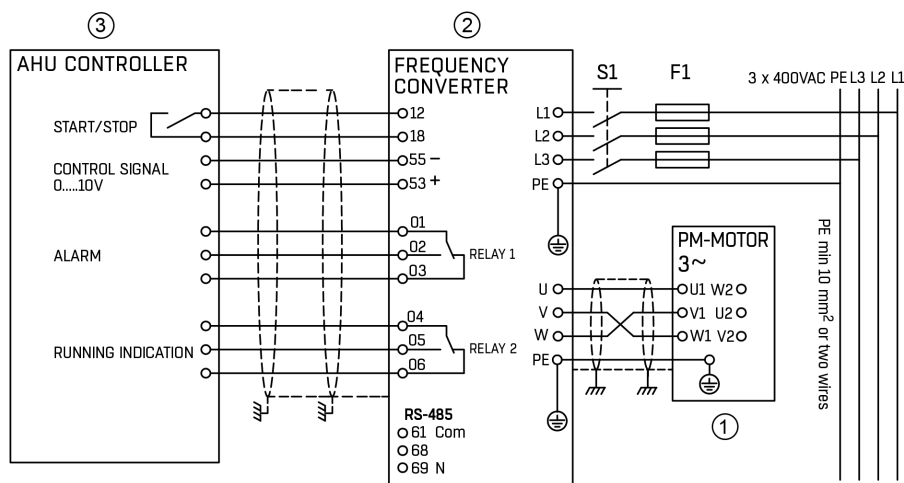

Figure 3.4.2.3 – FC101 and FC102 frequency inverter, AHU controller and PM motor connection diagram:

(1) – PM motor; (2) – Frequency converter; (3) – AHU controller.

PM motor control terminals and functions:

| TERMINAL NUMBER | FUNCTION | CONFIGURATION | FACTORY SETTING |
|-----------------|---------------|---------------|-----------------|
| 12 | +24 V output | | |
| 18 | Digital input | *PNP/NPN | Start |
| 19 | Digital input | *PNP/NPN | No operation |
| 20 | Com | | |
| 27 | Digital input | *PNP/NPN | Coast inverse |

| TERMINAL NUMBER | FUNCTION | CONFIGURATION | FACTORY SETTING |
|-----------------|---------------|--------------------------|-------------------|
| 29 | Digital input | *PNP/NPN | Jog |
| 50 | +10 V output | | |
| 53 | Analog input | *0-10 V/0-20 mA/ 4-20 mA | Ref1 |
| 54 | Analog input | *0-10 V/0-20 mA/ 4-20 mA | Ref2 |
| 55 | Com | | |
| 42 | 12 bit | *0-20 mA/4-20 mA/DO | Analog |
| 45 | 12 bit | *0-20 mA/4-20 mA/DO | Analog |
| 1, 2, 3 | Relay 1 | 1,2 NO 1,3 NC | [9] Alarm |
| 4, 5, 6 | Relay 2 | 4,5 NO 4,6 NC | [5] Drive running |

* indicates default setting

Note: PNP/NPN is common for terminals 18, 19 and 27

Installation Checklist

Before completing installation of the unit, inspect the entire installation as detailed in Table below. Check and mark the items when completed:

| INSPECT FOR | DESCRIPTION |
|-------------------------------|---|
| Auxiliary equipment | <ul style="list-style-type: none"> Look for auxiliary equipment, switches, disconnects, or input fuses/circuit breakers that may reside on the input power side of the frequency converter or output side to the motor. Ensure that they are ready for full-speed operation Check function and installation of any sensors used for feedback to the frequency converter Remove any power factor correction caps on motor(s) Adjust any power factor correction caps on the mains side and ensure that they are dampened |
| Cable routing | <ul style="list-style-type: none"> Ensure that motor wiring and control wiring are separated or screened or in 3 separate metallic conduits for high-frequency interference isolation |
| Control wiring | <ul style="list-style-type: none"> Check for broken or damaged wires and loose connections Check that control wiring is isolated from power and motor wiring for noise immunity Check the voltage source of the signals, if necessary The use of screened cable or twisted pair is recommended. Ensure that the shield is terminated correctly |
| Cooling clearance | <ul style="list-style-type: none"> Measure that top and bottom clearance is adequate to ensure proper air flow for cooling. |
| Ambient conditions | <ul style="list-style-type: none"> Check that requirements for ambient conditions are met |
| Fusing and circuit breakers | <ul style="list-style-type: none"> Check for proper fusing or circuit breakers Check that all fuses are inserted firmly and are in operational condition and that all circuit breakers are in the open position |
| Grounding | <ul style="list-style-type: none"> Check for sufficient ground connections that are tight and free of oxidation Grounding to conduit, or mounting the back panel to a metal surface, is not a suitable grounding |
| Input and output power wiring | <ul style="list-style-type: none"> Check for loose connections Check that motor and mains are in separate conduit or separated screened cables |
| Panel interior | <ul style="list-style-type: none"> Inspect that the unit interior is free of dirt, metal chips, moisture, and corrosion Check that the unit is mounted on an unpainted, metal surface |
| Switches | <ul style="list-style-type: none"> Ensure that all switch and disconnect settings are in the proper positions |
| Vibration | <ul style="list-style-type: none"> Check that the unit is mounted solidly, or that shock mounts are used, as necessary Check for an unusual amount of vibration |

NOTE: For more information, control, maintenance, diagnostics and troubleshooting refer to PM motors technical specification.

4. CABLE SELECTION AND CABLE INSTALLATION

4.1. THREE PHASE RECEIVER POWER SUPPLY CABLE SELECTION

Various conditions must be evaluated before selecting cable cross-section area:

- Power;
- Current;
- Starting currents;
- Operating conditions;
- Voltage drop;
- Mounting type;
- Ambient temperature;

Current-carrying capacity of PVC insulated copper conductors or cables under steady-state conditions in an ambient air temperature of +40 °C for different methods of installation (EN 60204-1:2006):

| Cross-sectional area, mm ² | INSULATION METHODS | | |
|---------------------------------------|--|------|------|
| | B2 | C | E |
| | Current-carrying capacity I for three phase circuits, A | | |
| 0,75 | 8,5 | 9,8 | 10,4 |
| 1,0 | 10,1 | 11,7 | 12,4 |
| 1,5 | 13,1 | 15,2 | 16,1 |
| 2,5 | 17,4 | 21 | 22 |
| 4 | 23 | 28 | 30 |
| 6 | 30 | 36 | 37 |
| 10 | 40 | 50 | 52 |
| 16 | 54 | 66 | 70 |
| 25 | 70 | 84 | 88 |
| 35 | 86 | 104 | 110 |
| 50 | 103 | 125 | 133 |
| 70 | 130 | 160 | 171 |
| 95 | 156 | 194 | 207 |
| 120 | 179 | 225 | 240 |

The voltage drop from the point of supply to the load shall not exceed 5 % of the nominal voltage under normal operating conditions. In order to conform to this requirement, it can be necessary to use conductors having a larger cross-sectional area than that derived from selection list.

Methods of conductor and cable installation independent of number of conductors/cables

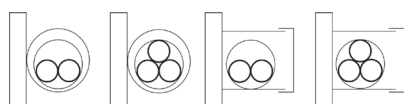

Figure 4.1.1 – B2 Cables in conduit and cable trunk systems

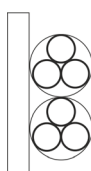

Figure 4.1.2 – C Cables on walls

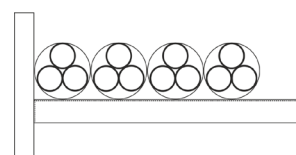

Figure 4.1.3 – D Cables on open cable trays

4.2. POWER AND CONTROL CABLE INSTALLATION

Shielded cables recommended during installation.

One end of the cable screen must be grounded at the control box ground terminal.

Power and control cables should be separated during installation (minimum distance 50 mm).

Separated cable ducts and different cable glands should be used for power and control cables.

5. HEAT RECOVERY SYSTEMS

5.1. PLATE HEAT EXCHANGER

In the plate heat exchanger, the warm extract air and the cool fresh air, separated by thin plates, pass each other in counter-flow. No mixing of the two air streams takes place. Therefore, the transmission of dirt, odours, moisture, bacteria, etc. is impossible. Heat transmitted from extract air to fresh air purely by conduction because of the temperature difference between the two air streams: the warm extract air cooled down and the cool fresh air heated up.

Heat exchanger section divided in separate parts from size 12-KR due transportation reasons. Refer to separate assembly manual for assembly of such section.

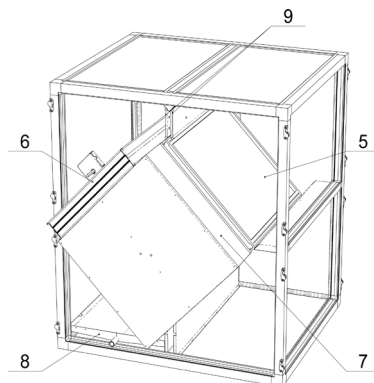

Figure 5.1.1 – Cross-flow heat exchanger section.

5 – Heat exchanger, 6 – by-pass damper, 7 – by-pass chamber, 8 – condensate tray, 9 – fixing bolts.

Plate heat exchanger is equipped with by-pass damper.

By-pass damper is controlled with modulating actuator (0-10V).

The actuator is controlled by means of a standard control signal DC 0 ... 10 V. It opens to the position dictated by this signal. The measuring voltage U allows the damper position (0 ... 100%) to be electrically indicated and serves as a follow-up control signal for other actuators.

Simple direct mounting on the damper spindle with a universal spindle clamp, supplied with an anti-rotation strap to prevent the actuator from rotating.

Manual operation is possible with the push-button (the gear is disengaged for as long as the button is pressed or remains locked).

Adjustable angle of rotation with mechanical end stops.

The actuator is overload-proof, requires no limit switches and automatically stops when the end stop is reached.

Safety notes:

Assembly must be carried out by trained personnel. Any legal regulations or regulations issued by authorities must be observed during assembly.

By-pass actuator electrical wiring diagram:

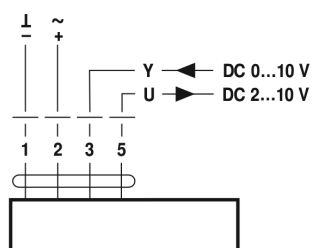

Figure 5.1.2 – Modulating actuator (0-10V) wiring diagram

The actuator rotation direction can be changed.

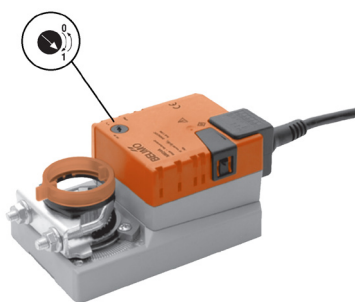
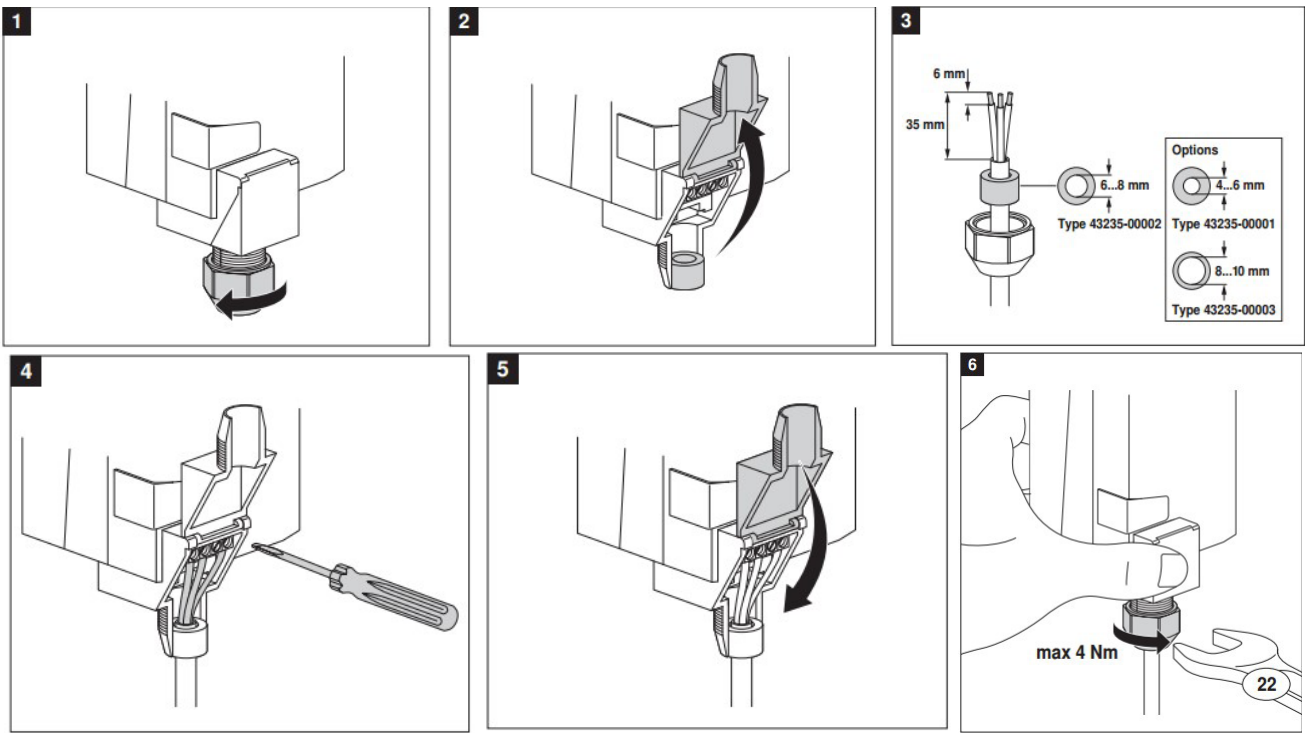

Figure 5.1.3 – Changing the rotation direction of the actuator

By-pass actuator electrical installation



NOTE: For more information, control, maintenance, diagnostics and troubleshooting refer to actuator technical specification.

For indoor swimming pool premises, by-pass damper actuator is selected with higher protection class (IP66/67). Optimum protection against corrosion and chemical influences, UV radiation, damp and condensation.



Figure 5.1.4 – Damper actuator with IP66/IP67 protection class

Before connecting power and control cables, actuators protective cover needs to be opened.

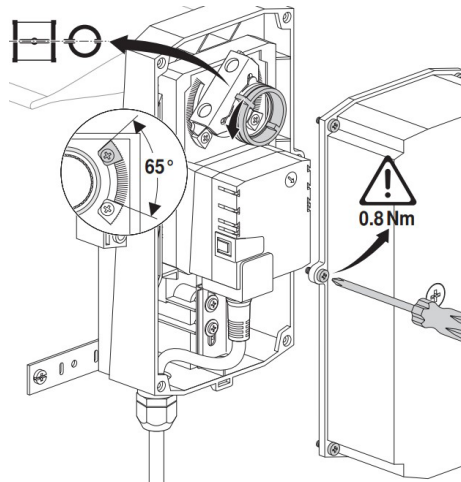

At the certain weather conditions the heat exchanger starts to freeze. Heat exchanger plates can be damaged during ice formation. To ensure it does not happens the heat exchanger is equipt with the pressure switch (relay). During ice formation air flow though heat exchanger plates decreases. Pressure builds up and the pressure switch is activated. Activated pressure switch indicates alarm and precautions must be taken.

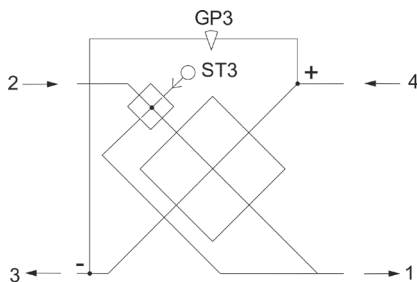

Figure 5.1.5 – Plate heat exchanger pressure switch and tubes mounting principal scheme:

GP3 – Heat exchanger pressure switch (relay) with „+“ and „-“ pressure tubes; ST3 – By-pass damper actuator; (1) – Supply air flow; (2) – Fresh air flow; (3) – Exhaust air flow; (4) – Extract air flow.

5.2. ROTARY HEAT EXCHANGER

Rotary heat exchangers are regenerators with rotating heat accumulators. The heat-dissipating and heat-absorbing air flows heat or cool the rotating, air-permeable storage accumulator. Depending on the air conditions and the surface of the accumulator material, moisture may also be transferred in the process. Self-cleaning effect due counter-flow supply. Double deck arrangement.

Rotary heat exchanger section divided in separate parts from size 12-KR due transportation reasons. Refer to separate assembly manual for assembly of such section.

Electrical connection:

- Electrical connection may only be undertaken by technically trained personnel.
- Rotors can be equipped with 1-phase motor (w/o control), 3-phase motor (w/o control) or stepping motor with controller.
- Do not route the wires through the heat exchanger’s casing. Otherwise it will be impossible to pull out heat exchanger in case the maintenance needed without help of electrician.

Important:

Some rotary heat exchangers are delivered with rubber transportation locks 6 which prevent rotor wheel from deformation. These rotary heat exchangers are marked with special warning label on the section. Remove rubber transportation locks before connecting rotary heat exchanger section to other section of the AHU otherwise the unit will not work properly.

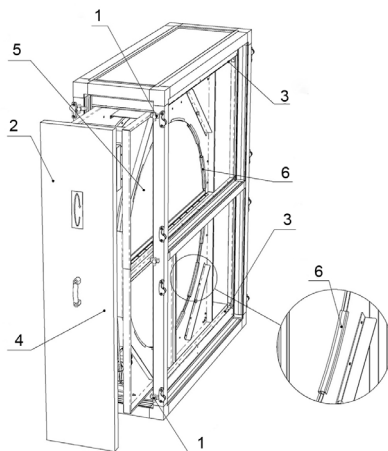

Figure 5.2.1 – Rotary heat exchanger section.

1 – Panel blocks, 2 – removable panel, 3 – fastening elements, 4 – casing, 5 – rotary heat exchanger, 6 - rubber transportation locks.

5.2.1. 1 ~ PHASE ROTOR MOTOR (W/O CONTROL)

Capacitor 1,5uF is used for motor connection. Capacitor is supplied with the motor as the device is delivered without any control system. Connection diagram and rotation direction of the single-phase induction motor:

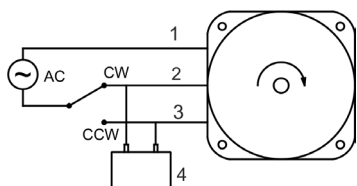

Figure 5.2.1.1 – Single-phase rotor motor connection - clockwise (CW) rotation:

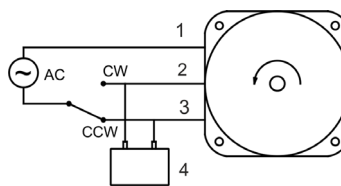

Figure 5.2.1.2 – Single-phase rotor motor connection - counter-clockwise (CCW) rotation:

(1) – Red (Main) wire; (2) - White wire; (3) – Black (blue) wire; (4) – Capacitor 1,5uF.

Recommended cable cross-sectional area (mm²) for connecting 1-phase rotor motor:

| CABLE CONDUCTOR CROSS-SECTIONAL AREA, mm ² | PURPOSE |
|---|--------------------------|
| 1,5 | Motor power supply cable |

NOTE: Rotor motor must be grounded. Ground wire must be connected to the ground screw at the motor junction box, and the other end of the wire must be connected to the ground loop of the device.

General:

If rotor does not rotate, check if:

- All cable connections (if any) are connected;
- Rotor motor is properly connected;
- Power supply voltage matches voltage indicated on the rotor motor plate;

After starting the device, inspect:

- Rotor rotation direction. It has to match to the direction of indicated sticker (if any);
- Operation of the rotation sensor (if any);

5.2.2. 3 ~ PHASE ROTOR MOTOR (W/O CONTROL)

Three phase single speed motors can normally be connected for two different voltage ranges (connection in star - higher voltage, or delta - lower voltage)

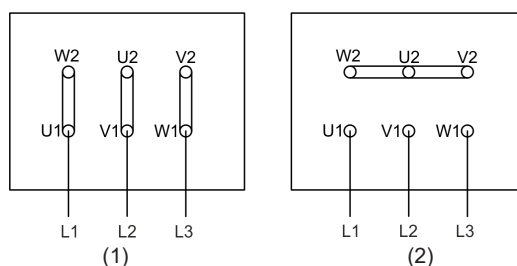

Figure 5.2.2.1 – AC motor (1 speed) wiring diagram for Delta (Δ) and Star (Y) connection.

(1) - Delta (Δ) connection 230V (400V); (2) - Star (Y) connection 400V (690V).

Thermal cut-outs

Thermal cut-outs is fitted to the motor winding. When the fixed temperature is exceeded the cut-out will break an electric circuit e.g. to a contactor which will turn off the motor. The switching contact is a temperature sensitive bimetal spring.

Thermal protection contacts of the motor (if any) must be connected using the terminals in the motor junction box.

Rotation direction

Three-phase rotor motor rotation direction can be changed by switching two of the power supply phases:

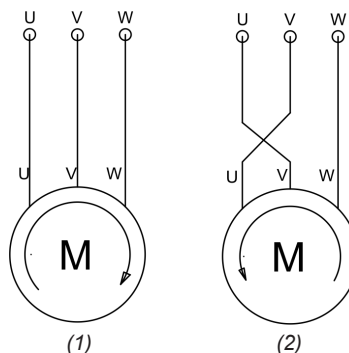

Figure 5.2.2.2 – Change of rotation for three-phase rotor AC motor:

(1) – clockwise (CW) rotation; (2) – counter-clockwise (CCW) rotation;

NOTE: Rotor motor must be grounded. Ground wire must be connected to the ground screw at the motor junction box, and the other end of the wire must be connected to the ground loop of the device.

NOTE: For more information, control, maintenance, diagnostics and troubleshooting refer to AC motors technical specification.

Recommended cable cross-sectional area (mm²) for connecting 3-phase rotor motor:

| CABLE CONDUCTOR CROSS-SECTIONAL AREA, mm ² | PURPOSE |
|---|-----------------------------|
| 1,5 | Motor power supply cable |
| 0,5 | Motor thermal cut-out cable |

NOTE: Rotor motor must be grounded. Ground wire must be connected to the ground screw at the motor junction box, and the other end of the wire must be connected to the ground loop of the device.

General:

If rotor does not rotate, check if:

- All cable connections (is any) are connected;
- Rotor motor is properly connected;
- Power supply voltage matches voltage indicated on the rotor motor plate;
- Thermal protection of the motor is activated (if any). When thermal protection is activated, contact becomes open (NO).

After starting the device, inspect:

- Rotor rotation direction. It has to match to the direction of indicated sticker (if any);
- Operation of the rotation sensor (if any);

Inductive rotation sensor

Single phase and three phase rotor (w/o control) can be equipped with inductive rotation sensor.

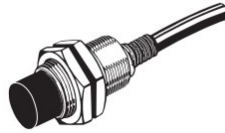

Rotation sensor can be used to identify if the rotor belt is broken or some other problems occurs.

Periodically perform the following checks to ensure stable operation of the sensor:

- Check for mounting position, dislocation, looseness, or distortion;
- Check for loose wiring and connections, improper contacts, and line breakage;
- Check for attachment or accumulation of metal powder or dust;
- Check for proper lighting of indicators (for models with a set indicator.)

Never disassemble or repair the Sensor.

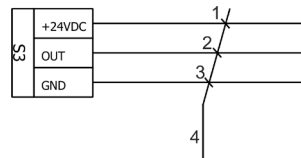

Figure 5.2.2.3 – Inductive rotor sensor electrical wiring connection scheme

(1) – Brown; (2) – Black; (3) – Blue; (4) – Inductive rotor sensor cable;

5.2.3. 5.2.3 STEPPING MOTOR WITH CONTROLLER

Step-motor and controller type depends on the size of the unit:

Step-motor controllers are OJ-DRHX series, EMX-R-..E or Varimax25;

Recommended cable cross-sectional area (mm²) for connecting step motor controller:

| CABLE CONDUCTOR CROSS-SECTIONAL AREA, mm ² | PURPOSE |
|---|-----------------------------|
| 1,5 | Motor power supply cable |
| 0,5 | Motor thermal cut-out cable |

OJ-DRHX series

The DRHX series covers the range from 2Nm to 14Nm with both Modbus and analogue control.

The DRHX is equipped with a software that monitors the rotation of the rotor, which means that no physical/optical rotor guard is required.

OJ-DRHX-2-8Nm

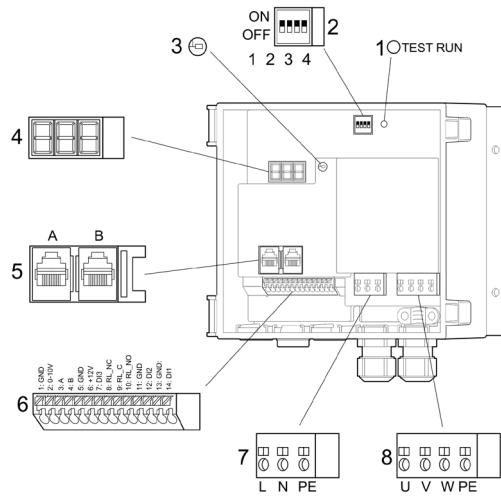

Figure 5.2.3.1 – step-motor controller OJ-DRHX-2-8Nm

| NO. | DESCRIPTION | NO. | DESCRIPTION |
|-----|--|-----|--|
| 1 | Test button | 5 | RJ12 Modbus connector (2 x RJ12) |
| 2 | 4-pole DIP switch | 6 | A/D control and signal terminals, depending on variant |
| 3 | LED | 7 | Supply terminals (L, N, PE) |
| 4 | 3 x 7-segment display - depending on variant | 8 | Connection terminals for stepper motor (U, V, W, PE) |

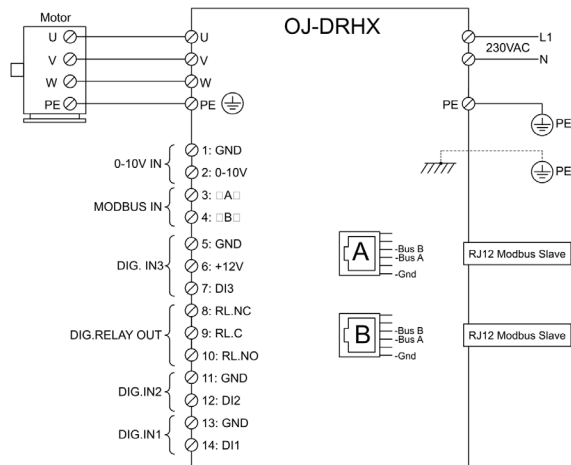

Figure 5.2.3.2 – step-motor controller OJ-DRHX 2-8Nm electrical connection scheme.

NOTE: The extension stepper motor cable should be connected to the terminals marked: “U” – Brown; “V” – Black; “W” – Blue; “PE” – Yellow/Green

OJ-DRHX-14Nm

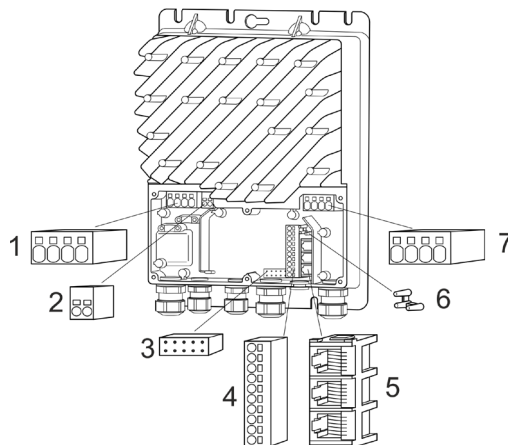

Figure 5.2.3.3 – step-motor controller OJ-DRHX-14Nm

| NO. | DESCRIPTION | NO. | DESCRIPTION |
|-----|---|-----|---|
| 1 | Stepper motor connections (U, V, W, PE) | 5 | RJ12 Modbus connector |
| 2 | Connection terminals for future use | 6 | 3-point strain relief for Modbus cable (ribbon cable) |
| 3 | Connector for optional module | 7 | Supply terminals (L, N, PE) |
| 4 | Terminal strip for Modbus and A/D control signals | 8 | Earth connection (PE) |

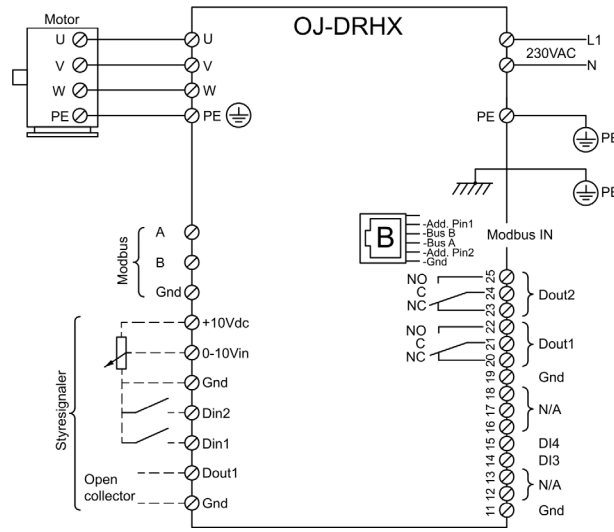

Figure 5.2.3.4 – step-motor controller OJ-DRHX-14Nm electrical connection scheme:

NOTE: The extension stepper motor cable should be connected to the terminals marked: “U” – Brown; “V” – Black; “W” – Blue; “PE” – Yellow/Green

| ITEM TO BE CHECKED | DESCRIPTION OF CHECK |
|---|---|
| Completion | Check that the entire installation is ready to be commissioned, both electrically and mechanically, before energizing the installation. |
| Check that no people or animals are present in the vicinity of moving parts. | |
| Check that the selected stepper motor size meets the required torque in order to be able to run the specific rotor. | |
| Check that the OJ-DRHX cover has been correctly fitted and that both snap locks have engaged correctly before energizing the product. | |
| Check that all unused cable glands and other unused openings are appropriately blanked off in accordance with the applicable enclosure rating. | |
| Check that the drive belt is tensioned correctly and that the rotor can rotate easily and unhindered, with a torque that is less than the rated torque for the stepper motor. | |
| Make sure that the belt is not tensioned beyond the maximum permissible vertical tension on the stepper motor shaft. | |
| Cabling | Check that all cabling has been fitted correctly and that stepper motor and control cables are kept apart in separate cable conduits. The motor cable must be fixed to the chassis of the rotor for its entire length |
| Check that all cables are securely attached and relieved of tension and torsion. | |
| Check that all cables are free of visible damage throughout their length. | |
| Electrical installation | Check that cables have been correctly inserted into OJ-DRHX and that the cable glands have been correctly tightened. |
| Check whether there are any bad electrical connections, as they may cause overheating and serious damage to the product and to property. | |
| Mains voltage | Check that the mains voltage wires have been correctly fitted to the supply terminals: one-phase on terminals “L”, “N” and “PE” and three-phase on terminals “L1”, “L2”, “L3” and “PE”. |
| Check by means of voltage measurement that there is the correct voltage on the terminals. | |
| Stepper motor connection | Check that the extension cable is properly connected to the OJ-DRHX terminals: “U”, “V”, “W” and “PE” |

| ITEM TO BE CHECKED | DESCRIPTION OF CHECK |
|---|--|
| Connector terminals, stepper motor and extension cable | Check that the connector terminals between the stepper motor cable and the extension cable are properly assembled and correctly engaged. The connector is properly assembled when the locking pawl on both sides of the connector on the motor cable is in firm connection with the connector on the extension cable. |
| Control and signal wires | Check that control cables are correctly terminated in the spring terminals and that the control cables are securely attached. (A/D control) |
| Check that both ends of the Modbus cable have been attached to the correct connectors. (Modbus control) | |
| Fuses and circuit breakers | Check that the active short-circuit protection is correctly inserted and dimensioned and complies with applicable local and international directives and regulations |
| Check that all safety equipment, including supplementary protection, is operative and set correctly. | |
| Earthing | Check by means of continuity measurement that the earth connection is active and that the contact resistance complies with applicable local and international directives and regulations. |

EMX-R-...E

EMX-R controller drive system consist of a motor and its associated control unit.

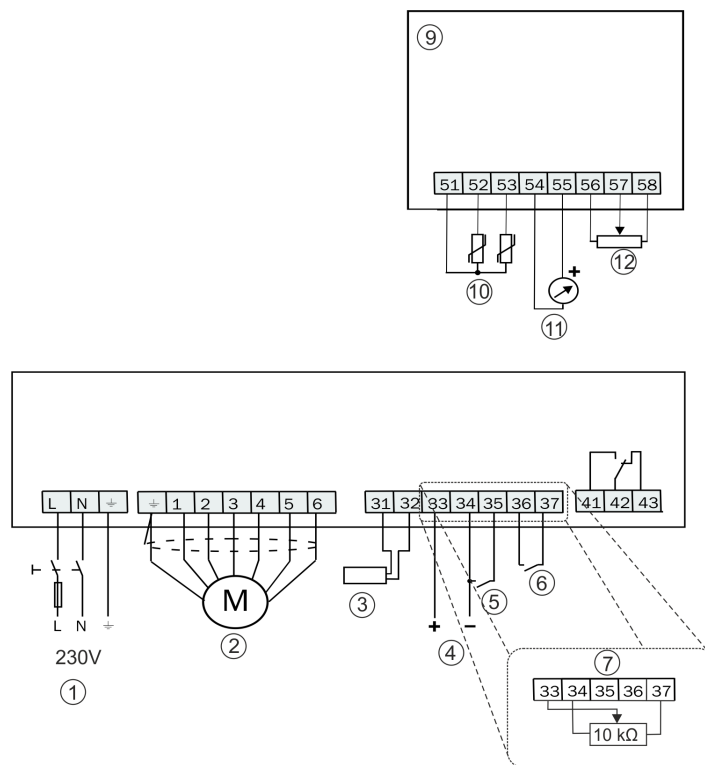

Figure 5.2.3.5 – step-motor controller EMX-R electrical connection scheme:

- (1) – Power supply 1~230VAC, 50Hz; (2) – Step motor; (3) –Rotation sensor; (4) –Control signal; (5) – Priority switch;
- (6) – Heat recovery on cooling; (7) – Manual control connection; (8) – Alarm relay 42-43 closed on alarm; (9) – Extra circuit board in model E;
- (10) – Heat recovery on cooling (51-52 incoming air sensor; 51-53 exhaust air sensor); (11) – Analog output signal (0-10V/20mA);
- (12) – Potenciometer control (100W – 5kW)

External sensor for rotation monitor (option)

The magnet for the rotation sensor is mounted onto the periphery of the heat exchanger. If the heat exchanger rotor cover is magnetic, the magnet must be insulated from the cover. The rotation sensor is mounted such that the magnet passes at a distance of 5–8 mm, see below.

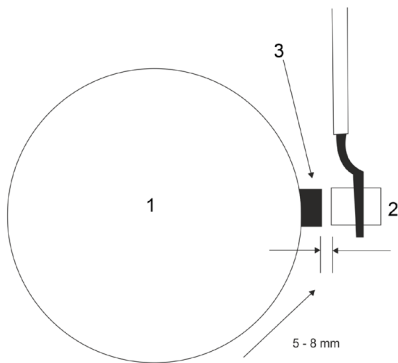

Figure 5.2.3.6 – rotation sensor mounting:

(1) – Rotor heat exchanger; (2) – Rotation sensor; (3) – Magnet;

The control unit is protected by monitoring for both over-voltage and undervoltage. If the supply voltage goes over or under the allowed limits, an alarm is triggered and the motor stops. The motor starts again automatically when the supply voltage returns to its normal value. The alarm is automatically reset.

The control unit has built-in motor protection that protects against overloading, and external motor protection is not required. Power supply to the motor is cut in the event of overload. In order to restart the drive system, the supply voltage to the control unit must be temporarily disconnected for at least 5 seconds.

Built-in short circuit protection protects against short circuits between the phases of the motor and between the phases and earth

Setting DIP switches for control signal:

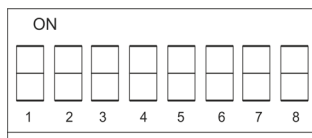

| | DIP switches | DIP switches | DIP switches |
|----------------|--------------|--------------|--------------|
| Control signal | 1 | 2 | 3 |
| 0-10V | ON | OFF | OFF |
| 2-10V | ON | OFF | ON |
| 0-20V | OFF | OFF | OFF |
| 4-40mA | ON | ON | ON |
| 0-20mA | ON | ON | OFF |

| | DIP switches | Speed controller | DIP switches | Direction of rotation | DIP switches |
|-------------------------------|--------------|------------------|--------------|-----------------------|--------------|
| Rotation monitor | 4 | | 5 | 6 | |
| With external rotation sensor | ON | V-belt | ON | Clockwise | OFF |
| RotoSens | OFF | Other belts | OFF | Counter-clockwise | ON |

| | DIP switches | DIP switches |
|-----------------------|--------------|--------------|
| Direction of rotation | 7 | 8 |
| 100 % | OFF | OFF |
| 80 % | OFF | ON |
| 60 % | ON | ON |

Varimax25

The VariMax25 is part of a range of control units adapted for optimum control of rotating heat exchangers, with the necessary additional functions. The VariMax25 control unit have an input signal of 0-10 V.

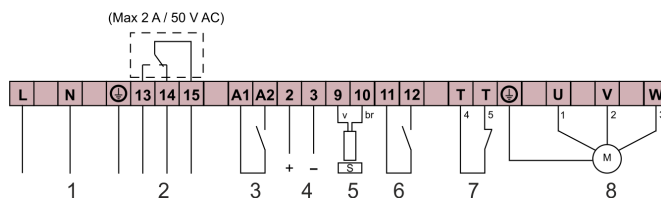

Figure 5.2.3.7 – step-motor controller VariMax25 electrical connection scheme:

(1) – Power supply 1~230VAC, 50Hz; (2) – Alarm relay; (3) – Man. speed; (4) – Input signal (0-10V); (5) – Rotation monitor; (6) – Reset; (7) – Thermal contact; (8) – Stepper motor 3-phase;

General for step motor drives:

Probable fault cause on installation:

- Magnet turned the wrong way
- Magnet transmitter incorrectly connected (wrong polarity), see electrical connection;
- Too big a gap between magnet transmitter and magnet;

Probable fault cause in operation:

- Broken belt;
- Belt slipping;
- Stuck wheel;
- The magnet transmitter or magnet is not intact;

6. HEAT EXCHANGERS

6.1. WATER HEATER

The water heaters designed for heating air with fluid as the heat carrier and mounted in the unit.

Water heater sections can be supplied with heat carrier temperature control point RMG. In case of built-in automation, connection of the water circulator pump and the three-way valve with actuator is designed.

Recommended cable cross-sectional area (mm²) for connecting water circulation pump and water valve actuator:

| CABLE CONDUCTOR CROSS-SECTIONAL AREA, mm ² | PURPOSE |
|---|------------------------------|
| 1,5 | Water circulation pump cable |
| 0,5 | Water valve actuator cable |

NOTE: Water circulation pump must be grounded. Ground wire must be connected to the ground screw at the motor junction box, and the other end of the wire must be connected to the ground loop of the device.

3-position control signal

- Voltage at Y1: Stem extends - Valve opens
- Voltage at Y2: Stem retracts - Valve closes
- No voltage at Y1 and Y2: Actuator maintains its current position

DC 0...10 V control signal

- The valve opens / closes in proportion to the control signal at Y.
- At DC 0 V, the valve is fully closed.
- When power supply is removed, the actuator maintains its current position.

Mounting water valve actuator

The mounting instructions are enclosed in the product packaging. Assembly is made with the union nut; no tools or adjustments are required. The actuator must be fitted in position 0 without operating voltage (also refer to actuator manual).

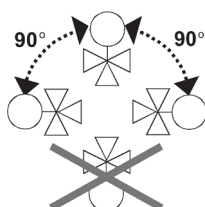

Self-calibration

During commissioning and whenever the operating voltage is switched on, the SSB61 runs a self-calibration routine. (Valve stroke 0 → Max. stroke → Setpoint). Never intervene manually in this process.

Manual override

To retain the manually set position, unplug the connecting cable or switch off power and the control signal.

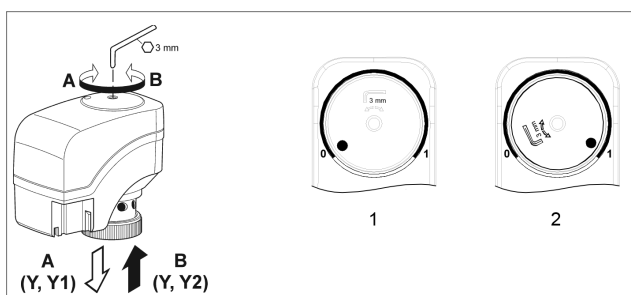

Figure 6.1.1 – Water valve actuator (SSB...) manual override

- (1) – Position indicator in position 0 = CLOSED;
- (2) – Position indicator in position 1 = OPEN;

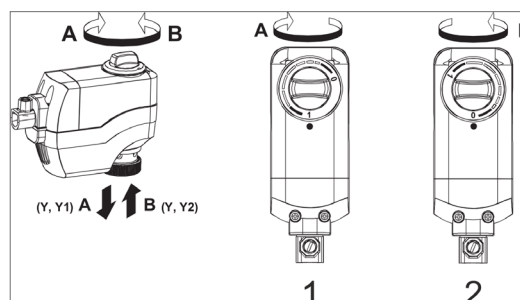

Figure 6.1.2 – Water valve actuator (SSC...) manual override

- (1) – Position indicator in position 1 = OPEN;
- (2) – Position indicator in position 0 = CLOSED

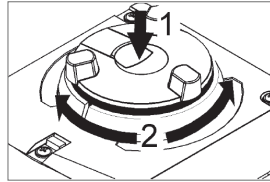

Figure 6.1.3 – Water valve actuator (SAX...) manual override

When pushing the manual adjuster down (1), it engages and the actuator can be manually operated. When turning the manual adjuster in a clockwise/counter-clockwise direction (2), the actuator's stem extends/retracts.

NOTE: For more information, control, maintenance, diagnostics and troubleshooting refer to water circulation pump and water valve actuator technical specification.

Water heater protection from freezing

During cold weather conditions water heater can freeze. Protection from potential freezing of heat carrier must be installed. Anti-freeze temperature sensor and thermostat are used for this purpose.

Anti-freeze temperature sensor is installed on the return pipe of the water. For mounting temperature sensor on the pipe - clip (hose clamp) is used.



Figure 6.1.4 – Installation of the anti-freeze temperature sensor

Capillary thermostat are electric circuit control devices which open or close an electric contact depending on temperature changes at the bulb. Capillary thermostat must be installed behind the water heater.

Capillary thermostat needs to be mounted inside air unit. If it is not possible, thermostat must be mounted inside box from dust protection and outside air temperature.

Capillary thermostat set point +5°C.

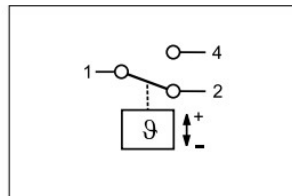

Figure 6.1.5 – Capillary thermostat electrical connection. On temperature rise above setting 1-2 opens and 1-4 closes; On temperature drop below setting 1-2 closes and 1-4 opens.

NOTE: When water heater is integrated in the unit, supply air damper actuator must be with the spring return. In case of the power supply failure, damper will close and water heater will be protected from freezing.

NOTE: For more information, control, maintenance, diagnostics and troubleshooting refer to capillary thermostat technical specification.

General:

If the valve actuator does not operate:

- Check connectors and contacts;
- Check if the actuator is connected properly and operating voltage is supplied;

Potential fault of the anti-freeze temperature sensor and thermostat:

- Check anti-freeze thermostat. In normal mode, environment temperature of the capillary must be higher than set on the thermostat. Contact between terminals 4 and 1 must be closed.
- If supply air temperature is low, the assemblies of the heating system must be inspected.

After starting the device, inspect if:

- The circulation pump rotates smoothly;
- The valve actuator is controlled smoothly;
- Control panel does not indicate faults of the anti-freeze protection (when the device has built-in control system);
- Water temperature sensor provides correct values;
- The thermostat is set at +5°C mark.

6.2. WATER COOLER

The water cooler designed for cooling air with fluid as the cold carrier and mounted in the unit.

Water cooler sections can be supplied with cold carrier temperature control point RMG. In case of built-in automation, connection of the water circulator pump and the three-way valve with actuator is designed.

For water circulation pump and valve actuator information refer to section “6.1. WATER HEATER”.

Water cooler temperature sensor is installed on the return pipe of the water. For mounting temperature sensor on the pipe - clip (hose clamp) is used.

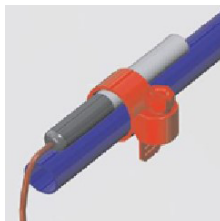



Figure 6.2.1 – Installation of the temperature sensor

6.3. ELECTRICAL HEATER

The electrical heaters designed for heating air by converting electrical energy to heat and mounted in the unit.

Connection:

- Electrical connection may only be undertaken by technically trained personnel.
- Before making the connections, compare the supply power technical specifications with the electric heater technical specifications (e.g. voltage, frequency).
- Electric heater technical specifications and connection diagram attached on the inner side of the heater cover.
- Electric heater must be grounded. Ground terminal or screw is designed for the heater and labelled with “PE” or symbol .
- Construction of power supply should be made so that voltage is supplied firstly to the fan and then to the electrical heater (to prevent overheating).
- Construction of power disconnecting should be so that voltage is disabled firstly from the electrical heater and then from the fan (to prevent overheating).

For electric heater power supply cable selection refer to section “4.2. POWER AND CONTROL CABLE INSTALLATION”.

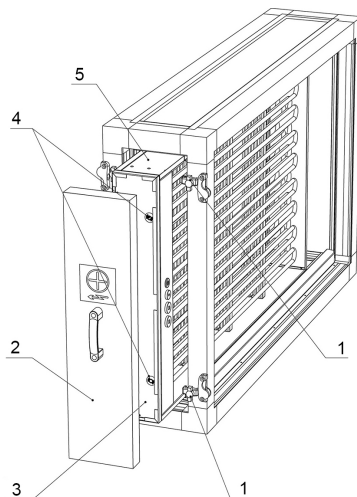

Figure 6.3.1 – Electric heater section.

1 – Panel blocks, 2 – removable panel, 3 – electrical heater cover, 4 – reset button (-s), 5 – electrical heater.

Two-stage overheat protection:

Overheat protection used to protect heater from overheating if airflow is too slow or system has a breakdown.

First stage (automatic) overheat protection activates at 50°C and reverses automatically when it cools down.

Second stage (manual) overheat protection activates at 100°C, it should be resettled manually by pressing “RESET” switch (-s).

If overheat protection activates:

- Disconnect heater from the mains supply.
- Analyse and eliminate reasons of activation overheat protections thoroughly.
- When failures are eliminated, restore manual overheat protection, i.e. push “RESET” switch (-s). For this purpose release panel blocks 1 and take off panel 2.
- Check if the heater works properly (no overheating).

General:

After starting the device, inspect if:

- All steps of the electric heater operates;
- Thermal protections are not activated;
- Circuit breaker is not switched off (because of current overload);
- Cables and wires do not touch heating elements;
- The cables and wires do not melt;

Establishment of malfunctions:

| MALFUNCTION | REASON OF MALFUNCTION | ELIMINATING MALFUNCTION |
|----------------------------|--|--|
| Full heating no regulation | Malfunction is in electrical circuit up to heater (controller, thermostat). | Check control devices and eliminate malfunction. |
| No heating | If there is no voltage on the contacts of heater then malfunction in electrical circuit up to heater (controller, fuses, thermostats, switches, etc.). | Check control devices and eliminate malfunction. |
| | If there is voltage on the contacts of heater then malfunction in overheat protections, heating elements. | Check contacts of overheat protections, measure voltage on heating elements and eliminate malfunction. |

6.4. GAS-FIRED HEATER

The gas-fired heater designed to heat air with natural or propane gas and mounted in the unit.

Gas-fired heater has its own control system.

Power supply and control signal needed for control.

Gas-fired heater controls type is on/off or 10V modulating.

NOTE: For more information, control, maintenance, diagnostics and troubleshooting refer to gas-fired heater technical specification.

7. HUMIDIFIERS

7.1. STEAM HUMIDIFIER

Immersed electrode humidifier for comfort air conditioning applications. Humidifier consist of humidifier cabinet placed near air handling unit and steam distributors installed inside air handling unit section with stainless steel drip tray or inside air ductwork. Two humidifier types available: X-plus and Basic.

Water and electrical connection:

Refer to manufacturer's operating instructions.

7.2. EVAPORATIVE HUMIDIFIER

Evaporative humidifier employ water evaporation produced by air currents. Used for air humidification or for indirect adiabatic cooling. Air passes through a sheet of water and partially evaporates it. The water vapour added to the air's mix, which is at the same time cooled.

Technical data:

- Units with recirculation in order to save water or direct water units to reduce maintenance work.
- Optional UV lamp water treatment system.

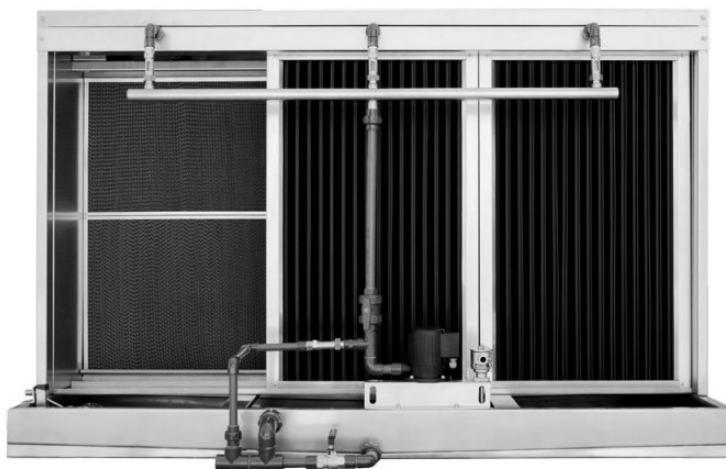

Figure 7.2.1 – Evaporative humidifier

Water and electrical connection:

Refer to manufacturer's operating instructions.

8. AIR FILTER SECTION

The air filters in a ventilation system prevent dust and other impurities reaching the premises. They also protect sensitive components in the air handling unit, such as air heaters, coolers and heat exchangers from contamination. Changing of filter should be primarily based on clogging, indicated by final pressure drop. Both visual inspection and monitoring of pressure drop is recommended.

Pressure drop indication:

Differential pressure switch or transmitter can be used for monitoring of filter contamination.

Pressure difference before and after the filter is generated, when filter performance of ventilation device changes.

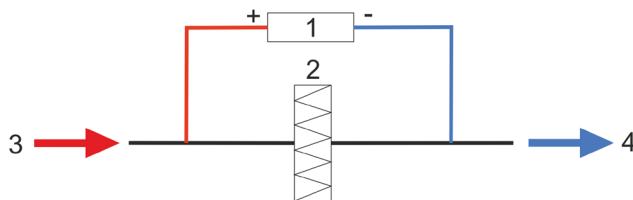

Figure 8.1 – Differential pressure switch / transmitter and pressure tubes mounting scheme with filter:

1 – Differential pressure switch / transmitter; 2 – Filter; 3 – Air flow before filter; 4 – Air flow after filter;

Differential pressure switch (digital output signal):

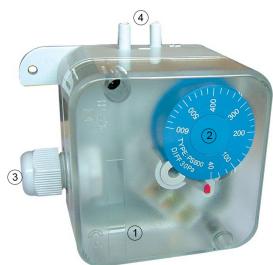

Figure 8.2 – Differential pressure switch

1 – Cover; 2 – Differential pressure selection wheel; 3 – Cable gland; 4 – Pressure tubes;

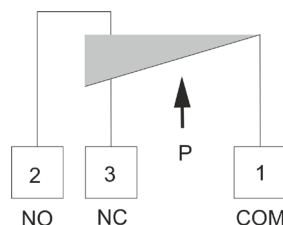

Figure 8.3 – Differential pressure switch wiring diagram:

NO – normally open; NC – normally closed; COM – common;

Differential pressure transmitter (analogue output signal):

The SPS series transmitters provide an analogue / digital output and eight selectable measuring windows. They are equipped with Modbus RTU communication. These make the units suitable for a wide range of applications. The SPS transmitters are calibrated and temperature & pressure compensated. They feature a high degree of reliability and accuracy.



Figure 8.4 – Differential pressure transmitter:

1 – Cover; 2 – Pressure tubes; 3 – Cable gland;

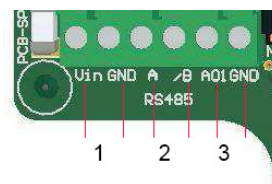

Figure 8.5 – Differential pressure transmitter wiring diagram:

1 – Power supply (13-26VAC/ 18-34VDC); 2 – Modbus RTU; 3 – Analogue output;

NOTE: For more information, control, maintenance, diagnostics and troubleshooting refer to differential pressure switch / transmitter technical specification.

9. DAMPER SECTION

The function of dampers is to control air supply to ducts, to close unit when the system is off, to prevent cold air to get in to the premises. Damper can be controlled manually with handle or automatically with actuator. Damper actuator control types: open / close or modulating (0-10V).

Open / close actuator:

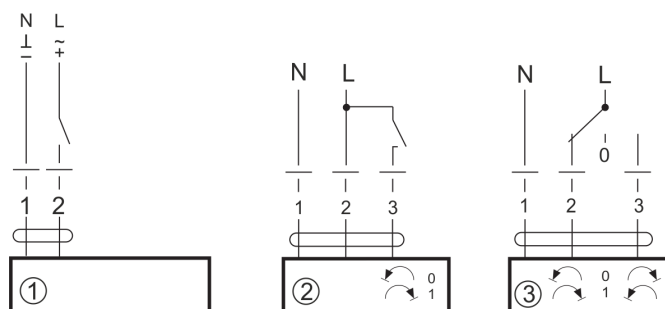

Figure 9.1 – damper actuator wiring diagram:

(1) – open-close with spring back actuator control; (2) – open-close actuator control; (3) – 3-point actuator control;

Modulating (0-10V) actuator:

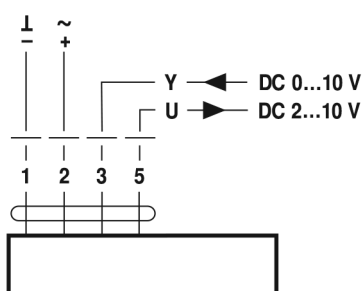

Figure 9.2 – Modulating actuator (0-10V) wiring diagram:

Simple direct mounting on the damper spindle with a universal spindle clamp, supplied with an anti-rotation strap to prevent the actuator from rotating.

Manual operation is possible with the push-button (the gear is disengaged for as long as the button is pressed or remains locked).

Adjustable angle of rotation with mechanical end stops.

The actuator is overload-proof, requires no limit switches and automatically stops when the end stop is reached.

The actuator rotation direction can be changed.

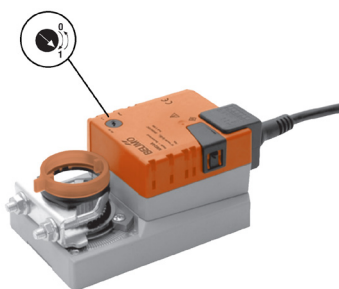
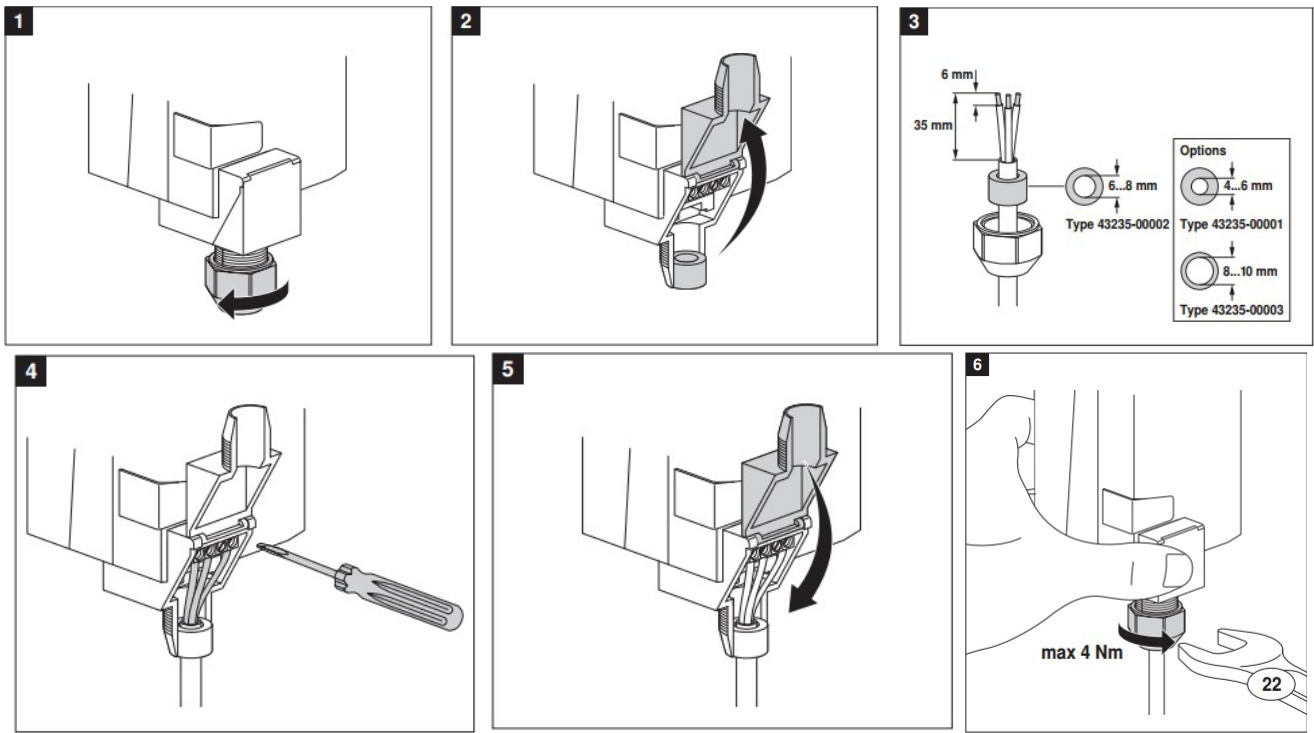

Figure 9.3 – Changing the rotation direction of the actuator

Safety notes:

Assembly must be carried out by trained personnel. Any legal regulations or regulations issued by authorities must be observed during assembly.

Actuator electrical installation



NOTE: For more information, control, maintenance, diagnostics and troubleshooting refer to actuator technical specification.

For indoor swimming pool premises, damper actuator is selected with higher protection class (IP66/67). Optimum protection against corrosion and chemical influences, UV radiation, damp and condensation.



Figure 9.4 – Damper actuator with IP66/IP67 protection class

Before connecting power and control cables, actuators protective cover needs to be opened.

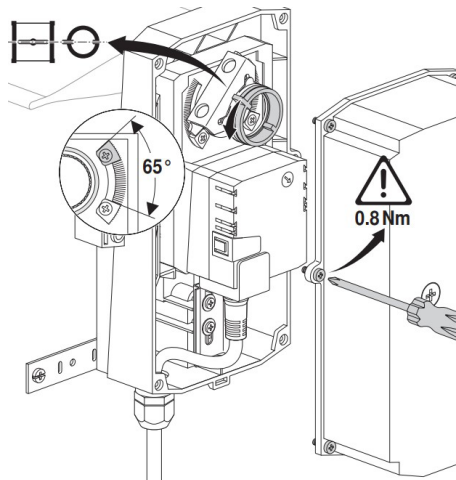

10. CONTROL SYSTEM

Control equipment customized according to every special customer need. All AmberAir units ordered with control system are factory configured and tested together with all the necessary field components.

Control system types:

- Built in control system. All components are in control section.
- Built in outside control system. Control cabinet mounted on the unit's doors or mounted on particular distance from the unit.
- Not built in control system.

NOTE: For built in outside control systems all cables (between control box and air handling unit) must be protected from direct UV, rain and mechanical influence.

Control system comes with:

- Electric part project;
- Main switch (for on/off main power supply);
- Control box ventilation fan (if needed);
- Control box heater (if needed);
- Protection components (circuit breakers, fuses);
- Control components (frequency inverters (if needed), contactors and relays (if needed));
- Additional components (modular socket);
- Controller;
- Terminals for cable connection;
- Cable glands;
- Sensors for air temperature and air quality control (if needed);

Safety notes:

Control system maintenance, control and troubleshooting must be carried out by trained personnel. Any legal regulations or regulations issued by authorities must be observed during assembly and operation.

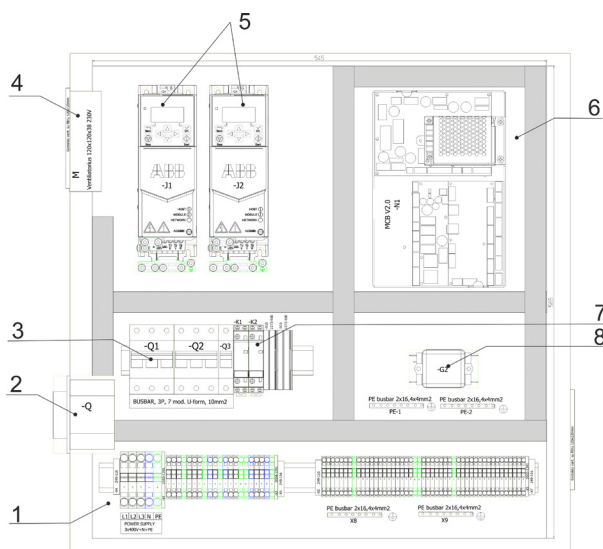

Figure 10.1 – Built in outside control cabinet sample:

- (1) – Terminals for cable connection; (2) – Control system main switch; (3) – Circuit breakers; (4) – Control system ventilation fan; (5) – Frequency inverters for fan control; (6) – Controller; (7) – Modular socket; (8) – Controller power supply filter.

Connecting main power supply cable to the control system:

Make sure main power supply is the same as the control system power supply (voltage, frequency).

Connecting different type of power supply can damage control system or AHU components.

Control system power supply is indicated in the electric part project or on the sticker inside control system.

Connect main power supply cable to the terminals or main power switch.

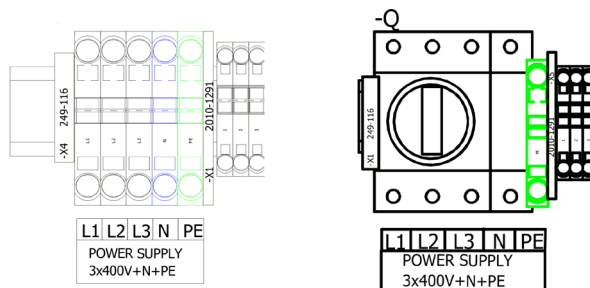

Figure 10.2 – Cable connection terminals and main switch:

From right - Terminals (for built in outside and for not built in control system); From left - Main power switch (for built in control system).

IMPORTANT: Control system must be grounded. Ground terminal is labelled with “PE” or symbol \oplus .

NOTE: Connecting power supply cable to the main switch make sure cable wires are tightened and secured from touching each other. During control system check inspect for power supply cable loose.

General

Before power supply is switched on to the control system, make sure:

- Control system is not damaged;
- All cable connections (if any) connected properly;
- All cables connected to the control system and not damaged;
- Control system is grounded;
- All circuit breakers turned on;
- Fan safety switch turned on (if any);
- All temperature and air quality sensors connected and mounted.

IMPORTANT: All control systems supplied with four pole main power switch (L1-L2-L3-N).

When main power switch is in OFF position, all three phases and neutral conductor will be disconnected from power supply.

There is electrical distribution system with TN-C network, when neutral conductor (N) cannot be disconnected from main power supply. In that case wire jumper is connected between earthing terminal (PE) and neutral terminal (N) on the air handling unit main power switch (Figure 10.3)

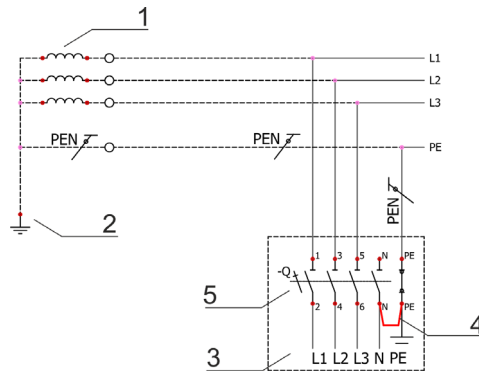
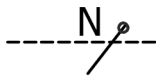

Figure 10.3 – Power supply connection to the air handling unit control box when electrical distribution system is with TN-C network:

- (1) – Power supply source; (2) – Earthing at power supply source; (3) – Air handling unit;
 (4) – Wire jumper between earthing terminal (PE) and neutral terminal (N); (5) – Air handling unit main power switch;

Marking symbols according to the standard IEC 60617-11:



Neutral conductor (N);



Protective conductor (PE)



Combined protective and neutral conductor (PEN)

11. ACCESSORIES

11.1. FAN SAFETY SWITCH

Safety switches are designed to be mounted near a motor to isolate it from the main circuit. They prevent accidental starting of electrical motor during maintenance or repair work. When safety switch in "OFF" position, it can be locked with a lock.

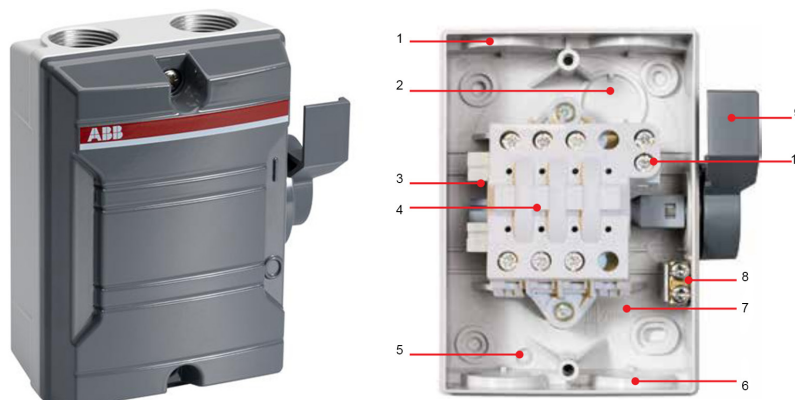

Figure 11.1.1 – Safety switch:

- (1) – Metric threaded knockouts; (2) – Knockout in the back of the box; (3) – Option for auxiliary contacts (NO/NC);
- (4) – Handle, axis and switch insert is one system factory assembled; (5) – Knockout for ventilation, water drain holes;
- (6) – IP54 cable glands sealing plugs included; (7) – Cable strip length; (8) – Terminals for 5-wire system: three phases + N + PE terminals;
- (9) – Handle padlockable in "O" position as standard. Knockout for padlock in "I" position;
- (10) – Isolated neutral terminal with separated in/out connection.

NOTE: For more information, installation and cable connection refer to safety switch technical specification.

11.2. SECTION LIGHTING

8W LED bulb lamp lighting optionally can be installed inside some sections (e.g. fans, filters). Lighting switch installed outside the section.

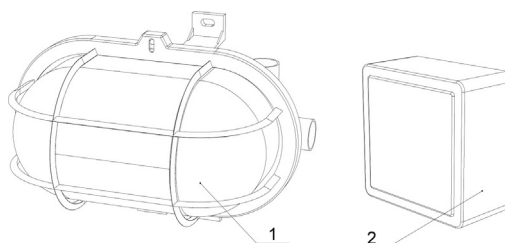

Figure 11.2.1 – Lighting: (1) – Lighting, (2) – Switch.

11.3. TEMPERATURE SENSORS (WITH INTEGRATED CONTROL SYSTEM)

Air handling units (only with integrated control system) are equipped with air temperature sensors.

Fresh air, extract air and exhaust air temperature sensors mounted inside unit.

Supply air temperature sensor mounted outside AHU with additional cable length (3m or 6m). During AHU installation supply air temperature sensor must be mounted in supply air duct as far as it is possible from heating elements (water, electric, gas heater). As a consequence, supplied air temperature to the premises is more accurate.

Air temperature sensor can be easily replaced in case of damage or failure.

Press connection terminals. Pull out sensor cable. Press connection terminals while inserting new temperature sensor cable.

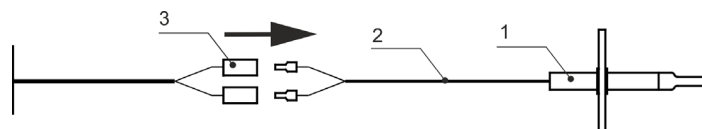

Figure 11.3.1 – Replacing air temperature sensor:

- (1) – Air temperature sensor; (2) – Sensor cable; (3) – Connection terminals;

11.4. DUCT SMOKE DETECTOR (WITH INTEGRATED CONTROL SYSTEM)

Possible spreading of fire between air handling unit and rooms through ducts must be prevented by control system using appropriate protection devices (e.g. smoke detectors).
 Units with control system can be equipped with smoke detector.
 Smoke detector has been developed to detect smoke in ventilation ducts.
 The duct detector contains an intelligent controlling circuit. This circuit is adjusting the sensitivity to give an optimal function during the whole life time of the detector. When the controlling circuit has reached the maximum sensitivity compensation for contamination, a service alarm is indicated.



Figure 11.4.1 – Duct smoke detector and waterproof cover

When installing outdoors or in cold attics etc, where there is a risk for condensation, the smoke detector should be insulated from the surrounding air with e.g. weatherproof housing.

NOTE: For more information, control, maintenance, diagnostics and troubleshooting refer to smoke detector technical specification.

11.5. CO₂ DUCT AND ROOM SENSOR (WITH INTEGRATED CONTROL SYSTEM)

Units with control system can be equipped with the CO₂ sensor which measures the concentration of CO₂ in ducts or premises. Four pre defined ranges provide ideal measurement windows with one user-definable range. The implemented NDIR sensor is self calibrating and maintenance-free. These sensors are equipped with Modbus RTU (RS485) communication and have an analogue output.



Figure 11.5.1 – CO₂ duct and room sensor

NOTE: For more information, control, maintenance, diagnostics and troubleshooting refer to CO₂ sensor technical specification.

11.6. HUMIDITY DUCT AND ROOM SENSOR (WITH INTEGRATED CONTROL SYSTEM)

Humidity sensor is designed for humidity detection. The calibrated humidity sensor measures the relative humidity of air and converts the measurements into standard signal (0-10V).



Figure 11.6.1 – Humidity duct and room sensor

NOTE: For more information, control, maintenance, diagnostics and troubleshooting refer to humidity sensor technical specification.

12. UNIT ASSEMBLING

If unit is with integrated control system, cable connectors must be connected between sections:

- Place unit section close to each other (approximately 0,2 m).
- Connect cable connectors.
- Every cable connector marked with numeric label.
- Connectors must be connected in accordance with their numbers. Connectors cannot be mixed.
- Connect unit sections together.

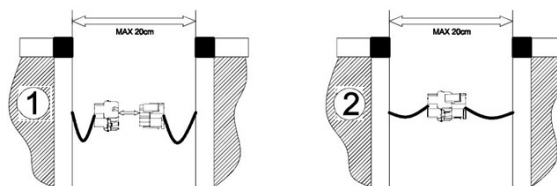

Figure 12.1 – Cable connection between sections



Figure 12.2 – Connector with numeric label

Sections of the device must be connected/disconnected in accordance with the safety requirements. If not observed, device can be damaged.

13. UNIT'S BASE FRAME GROUNDING

Fully assembled unit's base frame must be grounded:

- Between base frames (Example: General grounding diagram – D);

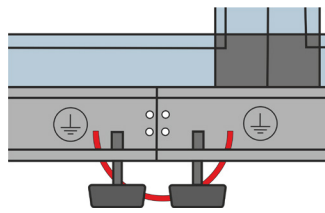

- Base of the fully assembled unit must be connected with the building grounding system (Example: General grounding diagram – F);

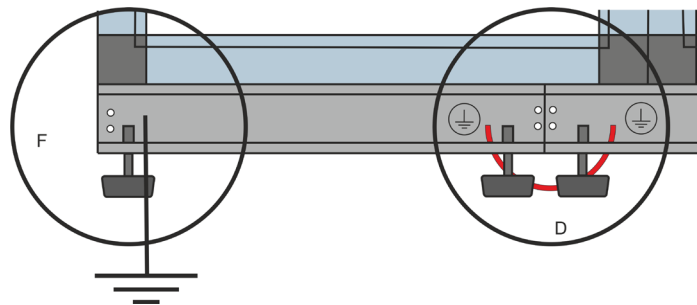

Figure 13.1 – Example of unit's base frame grounding diagram

14. CHECKLIST FOR UNIT START-UP AND MAINTENANCE

Periodically check, clean and repair (if necessary) all AHU components. Proper maintenance ensures a long service life of the unit. Document and keep all maintenance works journal in a well-known place.

- Device can be started only by trained and qualified personnel;
- Unit (with built-in control system) is prepared for work only when voltage is supplied to control panel and selected accessories are connected and when ventilation device is fully connected to the duct system;
- Before starting device, inspect:

| FUNCTIONAL COMPONENT OF THE DEVICE | INSPECTED ITEMS |
|------------------------------------|-----------------|
|------------------------------------|-----------------|

| | |
|----------------------------|--|
| Supply and extract air fan | Check cable connectors |
| | Check if there are no foreign objects or waste in the fan section. If yes, remove it. |
| | Check if the fan is connected to the power source in accordance with the basic connection diagram. Pay special attention to the thermal protections. |
| | Check if the bearings of fans rotate freely (move blades by hand). |
| | Check if cables used for connecting fan meet the safety requirements and long term current load capacity (A) |
| | Check fan grounding |
| | Check if fans safety switch is turned ON ** |
| Electric heater ** | Check if fan is attached firmly. |
| | Check connectors of the electric heater connection cable. |
| | Check if there are no foreign objects or waste in the heater section. If yes, remove. |
| | Check if cables used for connecting electric heater meet the safety requirements and long term current load capacity (A). |
| | Check if the electric heater is connected to the power source in accordance with the basic connection diagram. Pay special attention to the connection of the thermal protections. |
| | Check grounding of the electric heater. |
| | Check if the tubes of the thermal protections of the electric heater do not contact the heating elements. |
| Water heater ** | Check if the cables are installed through the seals of the electric heater. If cables do not contact the heating elements. |
| | Check if fully connected and filled water heater does not leak. |
| | Check if anti-freeze protections is properly installed and connected. |
| | Check if anti-freeze temperature sensor is attached on the return pipe of the water heater. |
| | Check capillary thermostat. It must be installed after the water heater and its adjustment knob must be turned at +5°C. |
| | Check if the actuator of the circulation pump and valve are connected in accordance with the basic electrical diagram. |
| | Check if the circulator pump is grounded. |
| Rotary heat exchanger ** | Check cable connectors of rotor motor. |
| | Check if there are no foreign objects or waste in the rotary heat exchanger section. If yes, remove. |
| | Check if cables used for connecting rotor motor meet the safety requirements and long term current load capacity (A). |
| | Check if the rotor motor is connected to the power source in accordance with the basic connection diagram. |
| | Check if the rotor motor is grounded. |
| | Check if the belt of the rotary heat exchanger is sufficiently tensioned, does not stuck and has no signs of mechanical damage. |
| | Check if the rotary heat exchanger is stable, rotates and is not stuck (move by hand). |
| Plate heat exchanger ** | Check if the rotor rotation sensor is installed and connected properly. Maximum distance between the sensor and rotor – 20 mm. ** |
| | Check if the cables do not contact and do not rub against the heat exchanger. |
| | Check if there are no foreign objects or waste in the plate heat exchanger section. If yes, remove. |
| | Check if the drainage system is installed correctly. If it does not leak. |
| | Check if the by-pass actuator of the plate heat exchanger is connected to the power source in accordance with the basic connection diagram. |
| | Check if by-pass valve of the plate heat exchanger opens smoothly. No jamming. |

FUNCTIONAL COMPONENT OF THE DEVICE INSPECTED ITEMS

| | |
|--|---|
| Control cabinet ** | <p>Check if the control cabinet is firmly installed on the device (when integrated externally).</p> <p>Check if there are no signs of damage outside and inside the control cabinet. Electrical components are not damaged and in place.</p> <p>Check if there are no foreign objects, waste, moisture or water inside the cabinet. If yes, remove.</p> <p>Check if the cables inside the control cabinet are connected in accordance with the basic connection diagram.</p> <p>Check if the main power supply cable meets the safety requirements and long term current load capacity (A).</p> <p>Check if main power supply cable is not damaged. Tightness and strength of the cable to the control cabinet is ensured.</p> <p>Check if control cabinet is grounded. Make sure ground wire is tightly connected and not loose.</p> |
| Temperature and air quality sensors ** | <p>Check cable connectors.</p> <p>Check if the sensors are connected in accordance with the basic connection diagram.</p> <p>Check if the sensors are not mechanically damaged.</p> <p>Check if the sensors are installed as intended (check labelling).</p> <p>Check if the sensors are not covered and do not contact foreign objects, which could influence the measurement.</p> |
| Damper, valve actuators ** | <p>Check if there are no trapped foreign objects in the dampers. If yes, remove.</p> <p>Check if the actuators are not mechanically damaged or deformed.</p> <p>Check if the actuators are connected in accordance with the basic connection diagram.</p> <p>Check cable connectors.</p> |

** - based on the unit type.



Ragainės g. 100
Šiauliai LT-78109, LITHUANIA

+370 41 540 415
cs@salda.lt



MAN000008